

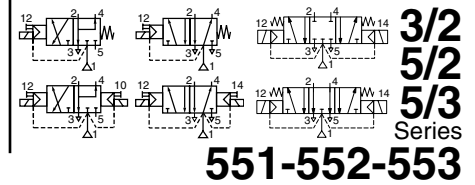

SPOOL VALVES

pilot operated or air operated, spool type
single/dual solenoid or air (mono/bistable function)
aluminium body, "NAMUR" style, 1/4 to 1/2



FEATURES

- The monostable spool valves have TÜV-EXIDA certified IEC 61508 Functional Safety data and can be used up to SIL 4 (551/TÜV)-SIL 3 (552-553/EXIDA)
- The spool valves have threaded port connections and "NAMUR" style interface
- The same spool valve can be adapted for 3/2 NC or 5/2 function for controlling double-acting and single-acting actuators
- All the exhaust ports of this spool valve are connectable, providing better environmental protection, particularly recommended for sensitive areas such as clean rooms, and applications in the pharmaceutical and food processing sectors
- The valve offers environmental protection against the ingress of liquids, dusts or any other foreign matter (environmentally-protected construction)
- Epoxy moulded coil for general service applications
- The solenoid valves satisfy all relevant EC Directives

GENERAL

Differential pressure 2 - 10 bar [1 bar = 100 kPa]
Flow (Qv at 6 bar) 1/4 = 700 l/min (ANR)
3/8 - 1/2 = 3000 l/min (5/2, 5/3)

fluids (*)	temperature range (TS)	seal materials (*)
air, inert gas, filtered	- 25°C to + 60°C	NBR (nitrile) + PUR (polyurethane)

MATERIALS IN CONTACT WITH FLUID

(*) Ensure that the compatibility of the fluids in contact with the materials is verified

Body	Aluminium, black anodized
End covers + interface plates	Glass-filled PA
Internal parts	Zamak, stainless steel, (POM), aluminium
Seals	NBR + PUR
Core and plugnut	Stainless steel
Shading coil	Copper

AIR OPERATED SPECIFICATIONS

pipe size	orifice size	flow coefficient kv		operating pressure differential (bar)			prefix option	basic catalogue number
				min.	max. (PS)			
(*)	(mm)	(m³/h)	(l/min)		air (*)			
					~	=		
3/2 NC - 5/2 - Air pilot operated - spring return (monostable)								
1/4	6	0,75	12,5	2	10	10	-	❖551A101 ⁽²⁾
3/8	12	2,49	41,5	2	10	10	-	❖552A101 ⁽²⁾
1/2	13	3,15	52,5	2	10	10	-	❖553A101 ⁽²⁾
3/2 NC - 5/2 - Air pilot operated and return (bistable)								
1/4	6	0,75	12,5	2	10	10	-	❖551A102
3/8	12	2,49	41,5	2	10	10	-	❖552A102
1/2	13	3,15	52,5	2	10	10	-	❖553A102

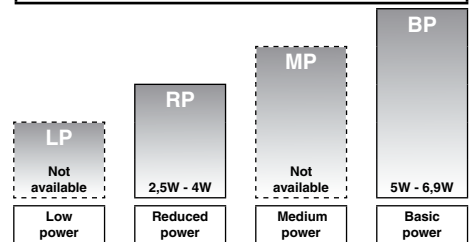
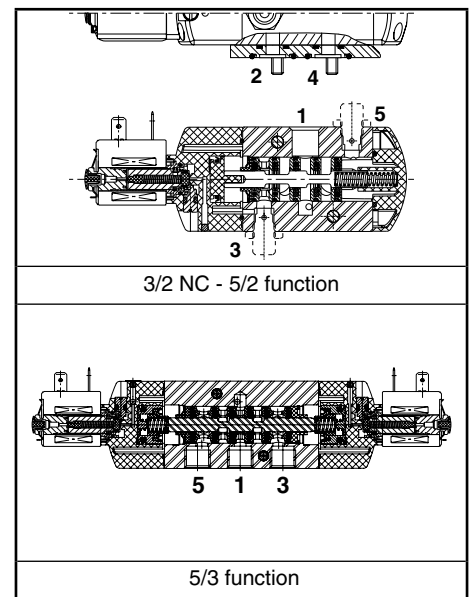

POWER LEVELS - cold electrical holding values (watt)

PILOT OPERATED SPECIFICATIONS 5/2

pipe size	orifice size	flow coefficient kv		operating pressure differential (bar)			power level	prefix optional solenoids				basic catalogue number		
				min.	max. (PS)			ATEX / IECEx			IP65			
(*)	(mm)	(m³/h)	(l/min)		air (*)		~/=	-	Ex e mb	Ex mb		-	SC	
					~	=								
3/2 NC - 5/2 - Solenoid air pilot operated - spring return (monostable)														
1/4	6	0,6	10	2	10	10	RP	-	●	-	-	●	❖551A001 ⁽²⁾	
1/4	6	0,6	10	2	10	10	RP	-	-	●	-	-	X❖551A001 20787 ⁽²⁾	
3/8	12	2,49	41,5	2	10	10	RP-BP	-	●	●	-	●	❖552A001 ⁽²⁾	
1/2	13	2,49	41,5	2	10	10	RP-BP	-	●	●	-	●	❖553A001 ⁽²⁾	
3/2 NC - 5/2 - Solenoid air pilot operated and return (bistable)														
1/4	6	0,6	10	2	10	10	RP	-	●	-	-	●	❖551A002	
1/4	6	0,6	10	2	10	10	RP	-	-	●	-	-	X❖551A002 20787	
3/8	12	2,49	41,5	2	10	10	RP-BP	-	●	●	-	●	❖552A002	
1/2	13	2,49	41,5	2	10	10	RP-BP	-	●	●	-	●	❖553A002	

❖ Select 8 for NPT ANSI 1.20.3 or select G for ISO G (228/1) ● Available feature - Not available
(2) Certified IEC 61508 Functional Safety data, use suffix "SL".

PILOT OPERATED SPECIFICATIONS 5/3

pipe size	orifice size	flow coefficient kv (m³/h) (l/min)		operating pressure differential (bar)			power level	prefix optional solenoids					basic catalogue number
				min.	max. (PS)			ATEX / IECEx				IP65	
					air (*)			-	Ex e mb	Ex mb	-		
(*)	(mm)				~	=	~/=	-	WBLP	PV	-	SC	
5/3 - W1 - pressure held, solenoid air pilot operated and return													
1/4	6	0,6	10	2	10	10	RP	-	●	-	-	●	❖551A065
1/4	6	0,6	10	2	10	10	RP	-	-	●	-	-	X❖551A065 20787
3/8	12	2,49	41,5	2	10	10	RP-BP	-	●	●	-	-	❖552A065
1/2	13	2,49	41,5	2	10	10	RP-BP	-	●	●	-	-	❖553A065
5/3 - W3 - pressure release, solenoid air pilot operated and return													
1/4	6	0,6	10	2	10	10	RP	-	●	-	-	●	❖551A066
1/4	6	0,6	10	2	10	10	RP	-	-	●	-	-	X❖551A066 20787
3/8	12	2,49	41,5	2	10	10	RP-BP	-	●	●	-	-	❖552A066
1/2	13	2,49	41,5	2	10	10	RP-BP	-	●	●	-	-	❖553A066

❖ Select 8 for NPT ANSI 1.20.3 or select G for ISO G (228/1) ● Available feature - Not available

PREFIX TABLE

prefix							description	power level			
1	2	3	4	5	6	7		LP	RP	MP	BP
P	V						Encapsulated epoxy moulded (EN/IEC 60079-18, 61241-18)*	-	●	-	●
W	B	L	P				I.S./encapsulation with PBT IP67 enclosure (EN/IEC 60079-7+18+21)*	-	●	-	-
S	C						Solenoid with spade plug connector (EN/IEC 60730)	-	●	-	●
						X	Other special constructions	-	●	-	●

SUFFIX TABLE

suffix					description	power level			
1	2	3	4	5		LP	RP	MP	BP
	G	D			Non-electrical, 2 GD c, construction safety, gas/dust (EN 13463-5)	-	-	-	-
		M	S		Screw type manual operator	-	●	-	●
				M	Exhaust reducer (series 551 only)	-	●	-	-
	S	L			Certified IEC 61508 Functional Safety data (1)	-	●	-	●

● Available feature

- Not available

* ATEX solenoids are also approved according to EN 13463-1 (non electrical valves)

(2) Not to use with MS suffix

PRODUCT SELECTION GUIDE

STEP 1

Select the fluid temperature range and seal material from the general table on page 1. Select basic catalogue number, including pipe thread identification letter. Refer to the specifications table on pages 1 and 2.

Example : G551A001

STEP 2

Select prefix (combination). Select the appropriate operator from the specifications table on page 1 and the prefix table on page 2. Select for this operator in the electrical characteristics table on page 3: the power level (RP, MP, BP), the type of electrical enclosure protection and the desired temperature class. The air operated version is without prefix.

Warning: The ambient temperature range of your application may not exceed the temperature range of your operator.

Do not use prefixes for air operated versions.

Example : SC

STEP 3

Select suffix (combination) if required. Suffix GD only applies for the air operated versions, do not use suffix MS.

Example : MS

STEP 4

Select voltage. Refer to standard voltages on page 3.

Example : 230V / 50Hz

STEP 5

Final catalogue / ordering number.

Example :

SC G551A001MS 230 V / 50 Hz

OPTIONS & ACCESSORIES

series	pipe size	exhaust protector (stainless steel)		
		(G)	(NPT)	(M)
551	1/8	34600418 (3)	34600482 (3)	-
551 (W1/W3)	1/4	34600419 (3)	34600483 (3)	-
552	3/8	34600478 (3)	34600480 (3)	-
553	1/2	34600479 (3)	34600481 (3)	-
551/552/553	M5	-	-	34600484 (3)

(3) Provided with "SL" suffix.

ORDERING EXAMPLES:

SC	G	551	A	001	MS	230V / 50 Hz
PV	X8	551	A	002	20787	115V / 50 Hz
WBLP	G	551	A	001	MS	24V / DC
SC	G	552	A	001	MS	24V / DC
		G	553	A	102	
		G	551	A	102	GD
		G	551	A	101	GD SL
SC	G	551	A	001	SL	230V / 50 Hz

prefix — pipe thread — basic number — voltage — suffix

EXPLANATION OF TEMPERATURE RANGES OF SOLENOID VALVES

Valve temperature range	The valve temperature range (TS) is determined by the selected seal material, the temperature range for proper operation of the valve and sometimes by the fluid (e.g. steam)
Operator ambient temperature range	The operator ambient temperature range is determined by the selected power level and the safety code
Total temperature range	The temperature range of the complete solenoid valve is determined by the limitations of both temperature ranges above

ELECTRICAL CHARACTERISTICS

Coil insulation class	F
Electrical safety	IEC 335
Standard voltages	DC (=) 24V - 48V AC (~) 24V - 48V - 115V - 230V/50Hz; other voltages and 60Hz are available on request

prefix option	power ratings				operator ambient temperature range (TS) (C°)	safety code	electrical enclosure protection (EN 60529)	replacement coil		type ⁽¹⁾
	inrush ~	holding ~		hot/cold =				~	=	
	(VA)	(VA)	(W)	(W)				230 V / 50 Hz	24 V DC	
Basic power = BP										
SC	15	7	5	5 / 6,9	-25 to +60	EN 60730	moulded IP65	43004649	43004647	02
PV	-	-	6,3	-/6,9	-40 to +65/40	II 2 G/D Ex mb IIC T3/Ex mD	moulded IP65	- ⁽⁴⁾	- ⁽⁴⁾	04
Reduced power (RP)										
SC	6	3,5	2,5	2,5/3,0	-25 to +60	EN 60730	moulded IP65	43004886	43004869	01
PV	-	-	4	-/3,0	-40 to +65/60	II 2 G/D Ex mb II T3/Ex mD	moulded IP65	- ⁽⁴⁾	- ⁽⁴⁾	03
WBLP	-	-	3,5	-/4	-40 to +65	II2G Ex e mb IIC T4, II2D Ex t IIC Db	IP67 PBT	- ⁽⁴⁾	- ⁽⁴⁾	05-06

⁽¹⁾ Refer to the dimensional drawings on page 4 (Air operated versions, see page 5 for types 7 and 8).

⁽⁴⁾ Multiple coil kits available under ATEX, contact us

ELECTRICAL CONNECTIONS

prefix	connection
SC	Spade plug connector with cable gland DIN 43650, 11 mm, industry standard B, for cables with an outer diameter from 6 to 8 mm (type 01) or EN175301-803A (ISO 4400) for cables with an outer diameter from 6 to 10 mm (type 02).
PV	Moulded-in cable, standard length 2 m
WBLP	M20 cable gland for cables with an outer diameter from 7 to 8,5 mm. With an internal and external facility for an earthing or bonding conductor

ADDITIONAL OPTIONS

- Other pipe threads are available on request
- Coil type CM25 with connector size 30 ISO 4400 (Pg 11P) (series 551)
- Polyamide coil
- Ex mb/mD (prefix "PV") solenoid can be supplied with various cable lengths
- Compliance with "UL" standard is available on request (552-553 ranges)
- Set of stainless steel mounting screws, catalogue number **97802212** (series 551)
- Set of two exhaust reducers, G1/8, catalogue number **88100344** (series 551)

INSTALLATION

- Installation/maintenance instructions are included with each valve
- The valves can be mounted in any position without affecting operation
- 3/2 NC-5/2 spool valve supplied with two interface plates with NAMUR mating surfaces. Depending on function (3/2 NC or 5/2), position one of the two plates on the spool valve body before installing on actuator
- IEC 61508 Functional Safety (Suffix SL), allowable temperature range: -25°C to +60°C. Probability of failure on demand, contact us
- Spool valve supplied with two interface plates with NAMUR mating surfaces. Depending on function (NC 3/2 or 5/2), position one of the two plates on the spool valve body before installing on actuator
- It is necessary to connect pipes or fittings to the exhaust ports to protect the internal parts of the spool valve and its pneumatic operator if used outside or in harsh environments (dusts, liquids etc.)
- Dowel pin (if necessary), bolts and gaskets are standard supplied
- Threaded pipe connection identifier is: 8 = NPT (ANSI 1.20.3); G = G (ISO 228/1)

DIMENSIONS (mm), WEIGHT (kg) (PILOT OPERATED VERSION)



TYPE 01:
SC
Epoxy moulded
IEC 335 / DIN 43650

551A001/A001MS/A002/A002MS



TYPE 02:
SC
Epoxy moulded
IEC 335 / ISO 4400

552A001/A001MS/A002/A002MS - 552A065/A065MS/A066/A066MS
553A001/A001MS/A002/A002MS - 553A065/A065MS/A066/A066MS

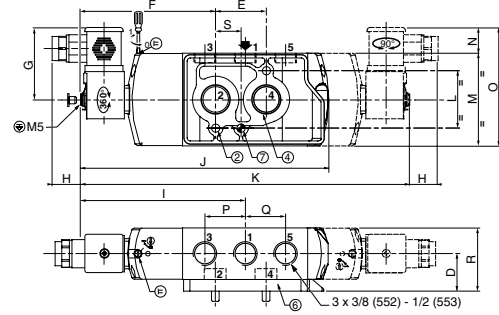
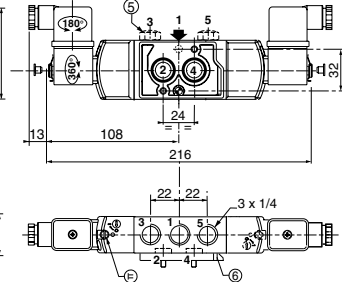
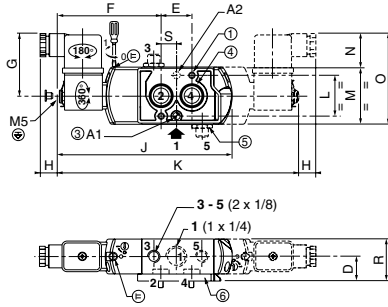

TYPE 03:
PV
Epoxy encapsulated
EN/IEC 60079-18 and EN/IEC 61241-18

551A001 20787/A001MS 20787
551A002 20787/A002MS 20787



TYPE 04:
PV
Epoxy encapsulated
EN/IEC 60079-18 and EN/IEC 61241-18

552A001/A001MS/A002/A002MS - 552A065/A065MS/A066/A066MS
553A001/A001MS/A002/A002MS - 553A065/A065MS/A066/A066MS

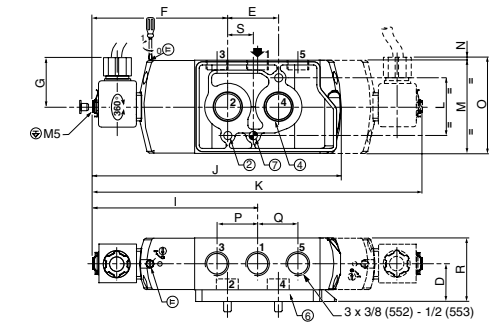
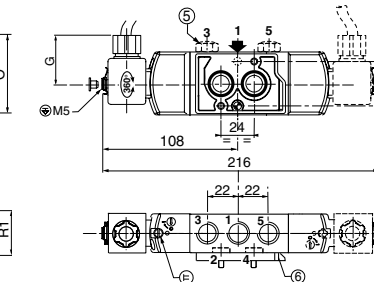
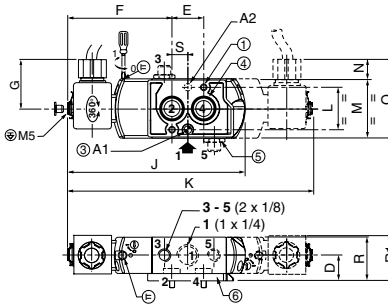

TYPE 05:
WBLP
PBT
EN/IEC 60079-7, EN/IEC 60079-18 and
EN/IEC 60079-31

551A001/A001MS/A002/A002MS



TYPE 06:
WBLP
PBT
EN/IEC 60079-7, EN/IEC 60079-18 and
EN/IEC 60079-31

552A001/A001MS/A002/A002MS - 552A065/A065MS/A066/A066MS
553A001/A001MS/A002/A002MS - 553A065/A065MS/A066/A066MS

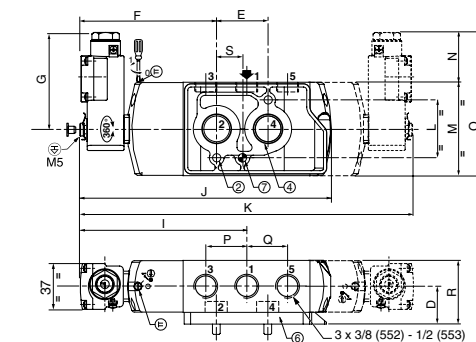
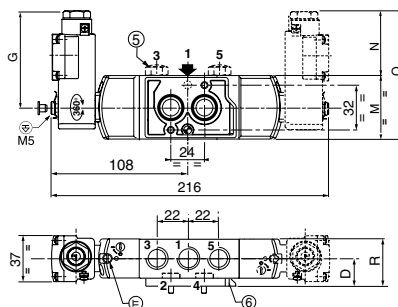
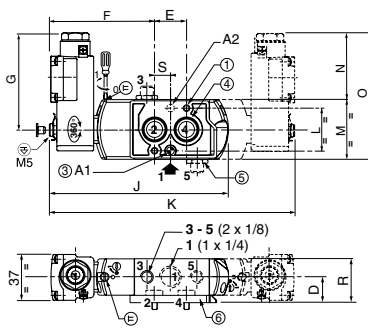

DIMENSIONS (mm), WEIGHT (kg) (AIR OPERATED VERSION)



TYPE 07:
No prefix, IP65
(suffixes, GD: II 2 GD c, SL: SIL
or GDSL: SIL, II 2 GD c)
Air operated version

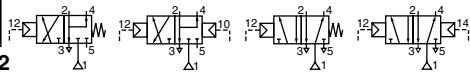

551A101 / 551A102

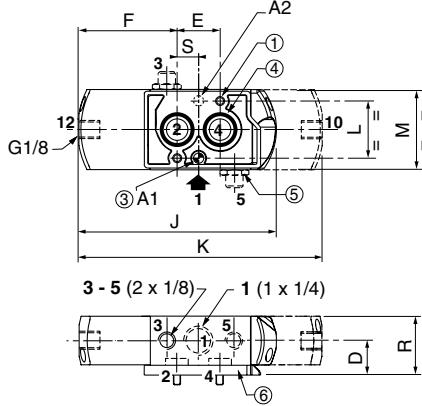

TYPE 08:
No prefix, IP65
(suffixes, GD: II 2 GD c, SL: SIL
or GDSL: SIL, II 2 GD c)
Air operated version

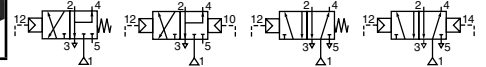

552A101 / 552A102 / 553A101 / 553A102

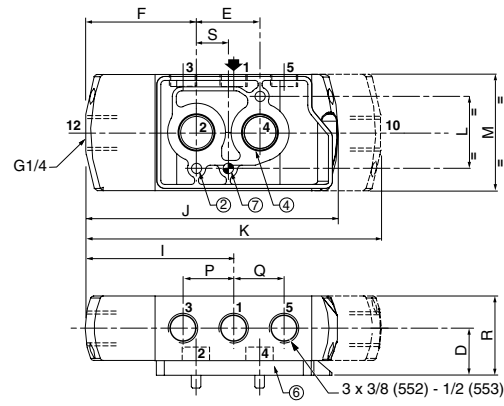

- ① 2 mounting holes dia. 5,3; Spotfacing: dia. 9, depth 5 mm
- ② 2 mounting holes dia. 6,5; Spotfacing: dia. 11, depth 6 mm
- ③ 1 dia. 5 mm hole for dowel pin (series 551)
- in position A1: 3/2 NC function plate
- in position A2: 5/2 function plate
- ④ 2 O-ring seals (supplied)
- ⑤ Exhaust reducers G 1/8 (series 551) or protectors adaptable on orifices 3 and 5
- ⑥ Interface plates
- ⑦ 1 dia. 6,5 mm hole for dowel pin (series 551-552). Same position for interface plate 3/2 NC or 5/2
- ⊕ Connectable pilot exhaust port

type	prefix option	power level	D	E	F	G	H	I	J	K	L	M	N	O	P	Q	R	R1	S	weight ⁽¹⁾	
																				(2)	(3)
01 (551)	SC	RP	19	24	83	49	13	-	139	192	32	45	27	72	-	-	33	-	12	0,34	0,46
02 (552)	SC	BP	29,1	40	106,7	56,2	21,8	129,3	197,5	261	45	72,3	20	92,3	29,6	29,7	49,2	-	20	0,91	1,21
02 (553)	SC	BP	29,1	40	106,7	56,2	21,8	130,3	197,5	261	45	72,3	20	92,3	31,6	31,8	49,2	-	20	0,90	1,20
03 (551)	PV	RP	19	24	83	36,5	-	-	139	192	32	45	13	58	-	-	33	36,5	12	0,38	0,50
04 (552)	PV	BP	29,1	40	106,7	36,5	-	129,3	197,5	261	45	72,3	0,3	72,6	29,6	29,7	49,2	-	20	0,94	1,24
04 (553)	PV	BP	29,1	40	106,7	36,5	-	130,3	197,5	261	45	72,3	0,3	72,6	31,6	31,8	49,2	-	20	0,93	1,23
05 (551)	WBLP	RP	19	24	83	81,5	-	-	139	192	32	45	59	104	-	-	33	36,5	12	0,38	0,50
06 (552)	WBLP	RP	29,1	40	106,7	81,5	-	129,3	197,5	261	45	72,3	45,35	117,65	29,6	29,7	49,2	-	20	0,94	1,24
06 (553)	WBLP	RP	29,1	40	106,7	81,5	-	130,3	197,5	261	45	72,3	45,35	117,65	31,6	31,8	49,2	-	20	0,93	1,23
07 (551)	-	-	19	24	-	-	-	-	107	128	32	45	-	-	-	-	33	-	12	0,31	0,41
08 (552)	-	-	29,1	40	70,7	-	-	129,3	161,5	189	45	72,3	-	-	29,6	29,7	49,2	-	20	0,86	1,12
08 (553)	-	-	29,1	40	70,7	-	-	130,3	161,5	189	45	72,3	-	-	31,6	31,8	49,2	-	20	0,85	1,11

⁽¹⁾ Types 1 to 4 : Including coil(s) and connector(s)

⁽²⁾ monostable

⁽³⁾ bistable

SECTIONAL DRAWINGS

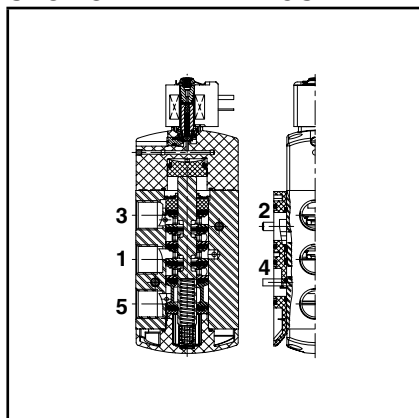

monostable 552 - 553 series

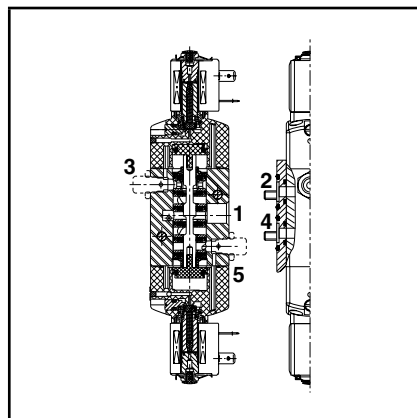

bistable 551 series

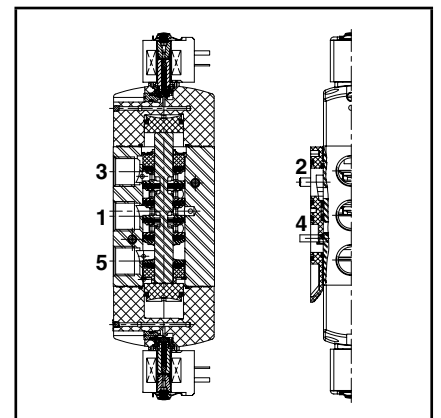

bistable 552 - 553 series

FEATURES

- The monostable spool valves have TÜV-EXIDA certified IEC 61508 Functional Safety data and can be used up to SIL 4 (551/TÜV)-SIL 3 (552-553/EXIDA)
- The spool valves have threaded port connections and "NAMUR" style interface
- The same spool valve can be adapted for 3/2 NC or 5/2 function for controlling double-acting and single-acting actuators
- All the exhaust ports of this spool valve are connectable, providing better environmental protection, particularly recommended for sensitive areas such as clean rooms, and applications in the pharmaceutical and food processing sectors
- The valve offers environmental protection against the ingress of liquids, dusts or any other foreign matter (environmentally-protected construction)
- Can be externally piloted (external air pilot supply) to convert valve to zero minimum operation by flipping a gasket
- The solenoid valves satisfy all relevant EC Directives

GENERAL

Differential pressure 2 - 10 bar [1 bar = 100 kPa]
Flow (Qv at 6 bar) 1/4 = 700 l/min (ANR)
 3/8 - 1/2 = 3000 l/min

fluids (*)	temperature range (TS)	seal materials (*)
air, inert gas, filtered	- 25°C to + 60°C	NBR (nitrile) + PUR (polyurethane)

MATERIALS IN CONTACT WITH FLUID

(*) Ensure that the compatibility of the fluids in contact with the materials is verified

Body	Aluminium, black anodized
End cover (spring)	Glass-filled PA
Interface plates	Glass-filled PA
Spool valve internal parts	Zamak, stainless steel, (POM), aluminium
Pilot internal parts	Refer to specific solenoid catalogue pages
Pilot end covers	Aluminium
Core tube	Stainless steel
Core and plugnut	Stainless steel
Core spring	Stainless steel
Seals	NBR
Top disc	PA
Disc holder	POM
Cartridge (low power)	Welded, packless AISI 430
Seat	Brass
Seat insert	POM
Shading coil	Copper
Rider rings (low power)	PTFE

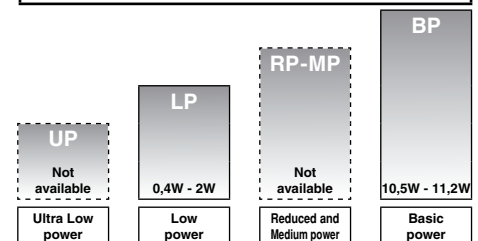
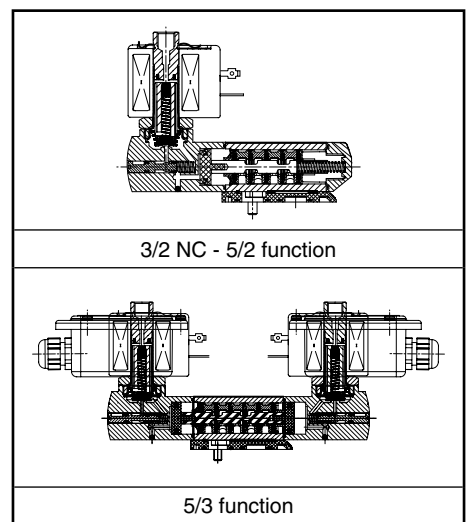

POWER LEVELS - cold electrical holding values (watt)

SPECIFICATIONS

pipe size	orifice size	flow coefficient kv		operating pressure differential (bar)			power level	prefix optional solenoids										basic catalogue number
				min. ⁽³⁾	max. (PS)			NEMA 7 & 9	ATEX / IECEx					IP65				
					air (*)				Ex d	Ex e mb	Ex mb	Ex ia	-					
(*)	(mm)	(m³/h)	(l/min)	~	=	~/=	EF	LPKF	NF	-	EM	PV	LI	IS	-	SC		
3/2 NC - 5/2 - Solenoid air pilot operated - spring return (monostable)																		
1/4	6	0,6	10	0 / 2	10	10	BP	-	-	●	-	●	-	-	-	●	❖551B401 ⁽²⁾	
1/4	6	0,6	10	0 / 2	10	10	BP	●	-	-	-	-	-	-	-	-	❖551H401 ⁽²⁾	
1/4	6	0,6	10	0 / 2	10	10	LP	-	●	●	-	●	○	○	○	-	●	❖551B301 ⁽²⁾
1/4	6	0,6	10	0 / 2	10	10	LP	○	-	-	-	-	-	-	-	-	-	❖551H301 ⁽²⁾
3/8	12	2,49	41,5	0 / 2	10	10	BP	-	-	●	-	●	-	-	-	-	●	❖552A401 ⁽²⁾
3/8	12	2,49	41,5	0 / 2	10	10	BP	●	-	-	-	-	-	-	-	-	-	❖552G401 ⁽²⁾
3/8	12	2,49	41,5	0 / 2	10	10	LP	-	●	●	-	●	○	○	○	-	●	❖552A301 ⁽²⁾
3/8	12	2,49	41,5	0 / 2	10	10	LP	○	-	-	-	-	-	-	-	-	-	❖552G301 ⁽²⁾
1/2	13	2,49	41,5	0 / 2	10	10	BP	-	-	●	-	●	-	-	-	-	●	❖553A401 ⁽²⁾
1/2	13	2,49	41,5	0 / 2	10	10	BP	●	-	-	-	-	-	-	-	-	-	❖553G401 ⁽²⁾
1/2	13	2,49	41,5	0 / 2	10	10	LP	-	●	●	-	●	○	○	○	-	●	❖553A301 ⁽²⁾
1/2	13	2,49	41,5	0 / 2	10	10	LP	○	-	-	-	-	-	-	-	-	-	❖553G301 ⁽²⁾

❖ Select **B** for NPT ANSI 1.20.3 or select **G** for ISO G (228/1) ● Available feature ○ Available feature in DC only - Not available
 (2) Certified IEC 61508 Functional Safety data, use suffix "SL".
 (3) Zero minimum is only achieved if external pressure is applied.

SPECIFICATIONS

pipe size	orifice size	flow coefficient kv		operating pressure differential (bar)			power level	prefix optional solenoids										basic catalogue number			
								min. ⁽³⁾	max. (PS)		NEMA 7 & 9	ATEX / IECEx					IP65				
				~	=	~/=			Ex d	Ex e mb		Ex mb	Ex ia	-	EF	LPKF			NF	-	EM
(*)	(mm)	(m³/h)	(l/min)																		
3/2 NC - 5/2 - Solenoid air pilot operated and return (bistable)																					
1/4	6	0,6	10	0/2	10	10	BP	-	-	●	-	●	●	-	-	-	●				❖551B402
1/4	6	0,6	10	0/2	10	10	BP	●	-	-	-	-	-	-	-	-	-	-	-	-	❖551H402
1/4	6	0,6	10	0/2	10	10	LP	-	●	●	-	●	○	○	○	-	●				❖551B302
1/4	6	0,6	10	0/2	10	10	LP	○	-	-	-	-	-	-	-	-	-	-	-	-	❖551H302
3/8	12	2,49	41,5	0/2	10	10	BP	-	-	●	-	●	●	-	-	-	●				❖552A402
3/8	12	2,49	41,5	0/2	10	10	BP	●	-	-	-	-	-	-	-	-	-	-	-	-	❖552G402
3/8	12	2,49	41,5	0/2	10	10	LP	-	●	●	-	●	○	○	○	-	●				❖552A302
3/8	12	2,49	41,5	0/2	10	10	LP	○	-	-	-	-	-	-	-	-	-	-	-	-	❖552G302
1/2	13	2,49	41,5	0/2	10	10	BP	-	-	●	-	●	●	-	-	-	●				❖553A402
1/2	13	2,49	41,5	0/2	10	10	BP	●	-	-	-	-	-	-	-	-	-	-	-	-	❖553G402
1/2	13	2,49	41,5	0/2	10	10	LP	-	●	●	-	●	○	○	○	-	●				❖553A302
1/2	13	2,49	41,5	0/2	10	10	LP	○	-	-	-	-	-	-	-	-	-	-	-	-	❖553G302
5/3 - W1 - pressure held, solenoid air pilot operated and return																					
1/4	6	0,6	10	0/2	10	10	BP	-	-	●	-	●	●	-	-	-	●				❖551B465
1/4	6	0,6	10	0/2	10	10	BP	●	-	-	-	-	-	-	-	-	-	-	-	-	❖551H465
1/4	6	0,6	10	0/2	10	10	LP	-	●	●	-	●	○	○	○	-	●				❖551B365
1/4	6	0,6	10	0/2	10	10	LP	○	-	-	-	-	-	-	-	-	-	-	-	-	❖551H365
3/8	12	2,49	41,5	0/2	10	10	BP	-	-	●	-	●	●	-	-	-	●				❖552A465
3/8	12	2,49	41,5	0/2	10	10	BP	●	-	-	-	-	-	-	-	-	-	-	-	-	❖552G465
3/8	12	2,49	41,5	0/2	10	10	LP	-	●	●	-	●	○	○	○	-	●				❖552A365
3/8	12	2,49	41,5	0/2	10	10	LP	○	-	-	-	-	-	-	-	-	-	-	-	-	❖552G365
1/2	13	2,49	41,5	0/2	10	10	BP	-	-	●	-	●	●	-	-	-	●				❖553A465
1/2	13	2,49	41,5	0/2	10	10	BP	●	-	-	-	-	-	-	-	-	-	-	-	-	❖553G465
1/2	13	2,49	41,5	0/2	10	10	LP	-	●	●	-	●	○	○	○	-	●				❖553A365
1/2	13	2,49	41,5	0/2	10	10	LP	○	-	-	-	-	-	-	-	-	-	-	-	-	❖553G365
5/3 - W3 - pressure release, solenoid air pilot operated and return																					
1/4	6	0,6	10	0/2	10	10	BP	-	-	●	-	●	●	-	-	-	●				❖551B466
1/4	6	0,6	10	0/2	10	10	BP	●	-	-	-	-	-	-	-	-	-	-	-	-	❖551H466
1/4	6	0,6	10	0/2	10	10	LP	-	●	●	-	●	○	○	○	-	●				❖551B366
1/4	6	0,6	10	0/2	10	10	LP	○	-	-	-	-	-	-	-	-	-	-	-	-	❖551H366
3/8	12	2,49	41,5	0/2	10	10	BP	-	-	●	-	●	●	-	-	-	●				❖552A466
3/8	12	2,49	41,5	0/2	10	10	BP	●	-	-	-	-	-	-	-	-	-	-	-	-	❖552G466
3/8	12	2,49	41,5	0/2	10	10	LP	-	●	●	-	●	○	○	○	-	●				❖552A366
3/8	12	2,49	41,5	0/2	10	10	LP	○	-	-	-	-	-	-	-	-	-	-	-	-	❖552G366
1/2	13	2,49	41,5	0/2	10	10	BP	-	-	●	-	●	●	-	-	-	●				❖553A466
1/2	13	2,49	41,5	0/2	10	10	BP	●	-	-	-	-	-	-	-	-	-	-	-	-	❖553G466
1/2	13	2,49	41,5	0/2	10	10	LP	-	●	●	-	●	○	○	○	-	●				❖553A366
1/2	13	2,49	41,5	0/2	10	10	LP	○	-	-	-	-	-	-	-	-	-	-	-	-	❖553G366

❖ Select **B** for NPT ANSI 1.20.3 or select **G** for ISO G (228/1) ● Available feature ○ Available feature in DC only - Not available
⁽³⁾ Zero minimum is only achieved if external pressure is applied.

PREFIX TABLE

prefix							description	power level			
1	2	3	4	5	6	7		LP	RP	MP	BP
E	F						Explosionproof - NEMA 7, 9 - Zinc plated steel conduit	○	-	-	●
E	M						Waterproof IP67 - Metal enclosure (EN/IEC 60079-7+18, 61241-1)*	●	-	-	●
		E	T				Threaded conduit/hole (M20 x 1,5)	●	-	-	●
I	S			S	C		Intrinsically safe with SC coil (EN/IEC 60079-11+26, 61241-11)*	○	-	-	-
L	P	K	F				Flameproof - Aluminium (EN/IEC 60079-1, 61241-1)*	●	-	-	-
N	F						Flameproof - Aluminium (EN/IEC 60079-1, 61241-1)*	●	-	-	●
P	V						Encapsulated epoxy moulded (EN/IEC 60079-18, 61241-18)*	○	-	-	●
S	C						Solenoid with spade plug connector (EN/IEC 60730)	●	-	-	●
W	P						Waterproof IP67 - Metal enclosure	●	-	-	●
L	I						I.S. with Aluminium IP67 enclosure (EN/IEC 60079-11 / 61241-1)*	○	-	-	-
W	S						Waterproof IP67 - 316 SS enclosure	●	-	-	●
W	S	L	P	K	F		Flameproof - 316 SS (EN/IEC 60079-1, 61241-1)*	●	-	-	-
W	S	E	M				Waterproof IP67 - 316 SS enclosure (EN/IEC 60079-7+18, 61241-1)*	●	-	-	●
W	S	N	F				Flameproof - 316 SS (EN/IEC 60079-1, 61241-1)*	●	-	-	●
		T					Threaded conduit (1/2" NPT)	●	-	-	●
				H	T		Class H - High temperature	-	-	-	●
						X	Other special constructions	●	-	-	●

- * ATEX solenoids are also approved according to EN 13463-1 (non electrical valves)
- Available feature
- Available feature in DC only
- Not available

SUFFIX TABLE

suffix							description	power level			
1	2	3	4	5	6	7		LP	RP	MP	BP
			M	O			Push type manual operator	●	-	-	●
					M		Exhaust reducer (series 551 only)	●	-	-	●
S	L						Certified IEC 61508 Functional Safety data ⁽¹⁾	●	-	-	●
M	F						Low temperature -40°C	●	-	-	●

- Available feature in DC only
- Not available
- ⁽¹⁾ Not to use with MO suffix

OPTIONS & ACCESSORIES

series	pipe size	exhaust protector (stainless steel)		
		(G)	(NPT)	(M)
551	1/8	34600418 ⁽²⁾	34600482 ⁽²⁾	-
551 (W1/W3)	1/4	34600419 ⁽²⁾	34600483 ⁽²⁾	-
552	3/8	34600478 ⁽²⁾	34600480 ⁽²⁾	-
553	1/2	34600479 ⁽²⁾	34600481 ⁽²⁾	-
551	M5	-	-	34600484

⁽²⁾ Provided with "SL" suffix.

ORDERING EXAMPLES:

SC	G	551	B	401	230V / 50 Hz	
SC	G	551	B	401	SL	230V / 50 Hz
SC	G	551	B	402	MO	230V / 50 Hz
SCHT	8	551	B	402	MO	230V / 50 Hz
ISSC	G	553	A	302	MO	24V / DC
LPKF	G	551	B	301	MO	24V / DC
WSLPKF	G	551	B	301	MO	24V / DC
ISSC	G	551	B	301		24V / DC
LI	G	552	A	301		24V / DC
EM	8	552	A	402	MO	230V / 50 Hz
EF	G	551	H	401	MO	240V / 60 Hz

prefix ⁽³⁾ pipe thread basic number ⁽³⁾ voltage suffix

⁽³⁾ Prefixes EF should always be used with the letter H or G in the basic number.

EXPLANATION OF TEMPERATURE RANGES OF SOLENOID VALVES

Valve temperature range	The valve temperature range (TS) is determined by the selected seal material, the temperature range for proper operation of the valve and sometimes by the fluid (e.g. steam)
Operator ambient temperature range	The operator ambient temperature range is determined by the selected power level and the safety code
Total temperature range	The temperature range of the complete solenoid valve is determined by the limitations of both temperature ranges above

ELECTRICAL CHARACTERISTICS

Coil insulation class	F
Electrical safety	IEC 335
Standard voltages	DC (=) 24V - 48V AC (~) 24V - 48V - 115V - 230V ⁽⁵⁾ /50Hz; other voltages and 60Hz are available on request

prefix option	power ratings				operator ambient temperature range (TS) (C°) ⁽¹⁾	safety code	electrical enclosure protection (EN 60529)	replacement coil / kit		type ⁽²⁾
	inrush	holding	hot/cold	=				~	=	
	(VA)	(VA)	(W)	(W)				230 V/50 Hz	24V/DC	
Basic power (BP)										
SC	55	23	10,5	9/11,2	-40 to +75	EN 60730	IP65 moulded	400425-117	400425-142	01
WP/WS	55	23	10,5	9/11,2	-40 to +75	EN 60730	IP67 steel/SS	400405-117	400405-142	04
NF/WSNF	55	23	10,5	-	(-60) ⁽⁷⁾ -40 to +25/40/60	II2G Ex d IIC T6/T5/T4, II2D Ex t	IP67 alu./SS	400405-117	-	02
NF/WSNF	-	-	-	9/11,2	(-60) ⁽⁷⁾ -40 to +40/60/75	II2G Ex d IIC T6/T5/T4, II2D Ex t	IP67 alu./SS	-	400405-142	02
EM/WSEM	55	23	10,5	9/11,2	-40 to +40	II2G Ex e mb II T3, II2D Ex tD	IP67 steel/SS	400909-117	400913-142	04
PV	55	23	10,5	9/11,2	-40 to +65	II2G Ex mb II T3(-)/T4(=), II2D Ex mD 21	IP67 moulded	- ⁽⁴⁾	- ⁽⁴⁾	05
EF	55	23	10,5	9/11,2	-40 to +54/40	NEMA type 7 and 9	NEMA 4X	238614-058	238714-006	06
Low power (LP)										
SC	1,5	1,5	1,5	1,7/1,7	-40 to +60	EN 60730	IP65 moulded	400925-097	400925-042	07
WP/WS	1,5	1,5	1,5	1,7/1,7	-40 to +60	EN 60730	IP67 steel/SS	400926-097	400926-042	09
LPKF/WSLPKF ⁽⁸⁾	2,4	2,4	2,4	0,5/0,5 ⁽⁸⁾	-40 to +80/60	II2G Ex d IIB+H2 Gb T4/T6, II2D Ex t Db	IP67 alu./SS	- ⁽⁴⁾	- ⁽⁴⁾	13
NF/WSNF	-	-	1,9	-/1,9	(-60) ⁽⁷⁾ -40 to +75/80	II2G Ex d IIC T6/T5, II2D Ex t	IP67 alu./SS	- ⁽⁴⁾ ⁽⁵⁾	- ⁽⁴⁾	08
EM/WSEM	1,5	1,5	1,5	1,7/1,7	-40 to +40/55	II2G Ex e mb II T6/T5, II2D Ex tD	IP67 steel/SS	- ⁽⁴⁾	- ⁽⁴⁾	09
PV	-	-	-	1,7/1,7	-40 to +65	II2G Ex mb II T6 / II2D Ex mD 21	IP67 moulded	-	- ⁽⁴⁾	10
EF	-	-	-	1,7/1,7	-40 to +60	NEMA type 7 and 9	NEMA 4X	-	- ⁽⁴⁾	11
ISSC ⁽³⁾	-	-	-	0,4/04	-40 to +60	II2G Ex ia IIC T6, II2D Ex iaD 21	IP65 moulded	-	268976-001	12
LI ⁽³⁾ ⁽⁶⁾	-	-	-	0,5/0,5	-40 to +60	II1G Ex ia IIC T6 Ga, II2D Ex t IIIC Db ⁽⁶⁾	IP67 alu.	-	- ⁽⁴⁾	14

prefix option	safety parameters				
	U _i = (DC) (V)	I _i (mA)	P _i (W)	L _i (H)	C _i (µF)
Low power (LP)					
ISSC	32	500	1,5	0	0
LI	32	500	1,5	0	0

- ⁽¹⁾ Temperature range can be limited by sealings
- ⁽²⁾ Refer to the dimensional drawings on pages: 11 to 14
- ⁽³⁾ ISSC/LI: Check the electrical characteristics in the corresponding catalogue pages
- ⁽⁴⁾ Multiple coil kits are available under ATEX/IECEx, contact us
- ⁽⁵⁾ (WS)NF: Low Power, 230 V AC does not exist. Maximum voltage in AC is 115 V
- ⁽⁶⁾ LI: Low Power, 24 V DC only (**For use in zone 0 locations, see the installation conditions given in the I&M instructions**)
- ⁽⁷⁾ The certified minimum temperature of this operator
- ⁽⁸⁾ LPKF/WSLPKF: 24 V DC, max. ambient temp. +80°C, contact us (48 V DC = 2,1 W)
- Not available

ELECTRICAL CONNECTIONS

prefix	connection
SC, ISSC	Spade plug connector with cable gland EN175301-803A (ISO 4400) for cables with an outer diameter from 6 to 10 mm
WP, WS, EM, WSEM	M20 cable gland for cables with an outer diameter from 7 to 12 mm. With an internal and external facility for an earthing or bonding conductor
NF, WSNF, LPKF, WSLPKF	1/2" NPT threaded cable entry. Enclosures are supplied without cable gland
PV	Moulded-in cable, standard length 2 m
LI	1/2" NPT cable gland for cables with an outer diameter from 7 to 12 mm. With an internal and external facility for an earthing or bonding conductor
EF	1/2" NPT conduits, standard length 35 cm

ADDITIONAL OPTIONS

- Valves configured for external pilot air supply, TPL 20547
- Other pipe threads are available on request
- Ex mb/mD (prefix "PV") solenoid can be supplied with various cable lengths
- Compliance with "UL", "CSA" and other local approvals available on request
- 1/2" NPT (prefix "T") and M20 x 1.5 (prefix "ET") conduits (aluminium or 316 SS) available for steel solenoid housing
- Set of stainless steel mounting screws, catalogue number: **97802212** (series 551)
- Set of two exhaust reducers, G1/8, catalogue number: **88100344** (series 551)

INSTALLATION

- Multi language installation/maintenance instructions are included with each valve
- The solenoid valves can be mounted in any position without affecting operation
- 3/2 NC-5/2 spool valve supplied with two interface plates with NAMUR mating surfaces. Depending on function (3/2 NC or 5/2), position one of the two plates on the spool valve body before installing on actuator
- Do not connect the pressure supply to the exhaust port 3. The "environmentally-protected" construction is not adapted for NO function. Contact us for function available in specific version
- Dowel pin (if necessary), bolts and gaskets are standard supplied
- IEC 61508 Functional Safety (suffix SL), allowable temperature range: -40°C to +60°C. For probability of failure, contact us
- It is necessary to connect pipes or fittings to the exhaust ports to protect the internal parts of the spool valve and its pneumatic operator if used outside or in harsh environments (dusts, liquids etc.)
- Threaded pipe connection identifier is: 8 = NPT (ANSI 1.20.3); G = G (ISO 228/1)
- Prefix "NF/WSNF" enclosure is provided with a 1/2" NPT threaded entry hole, M20 x 1,5 (prefix "ET") is optional. Both are supplied without cable gland
- To comply with IEC 61508 (SIL) the valves must be provided with a specific exhaust protector (see following pages)

DIMENSIONS (mm), WEIGHT (kg)

Series 551

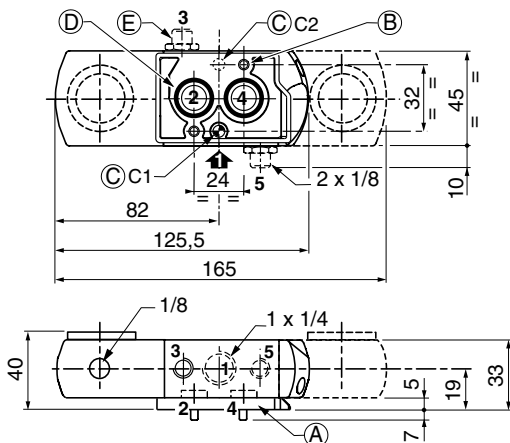

Series 551 (W1, W3)

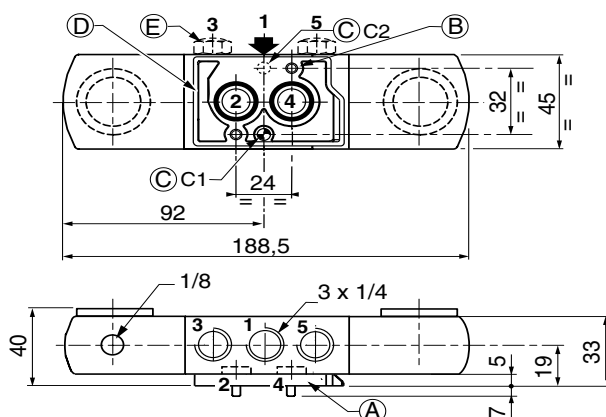

Series 552-553

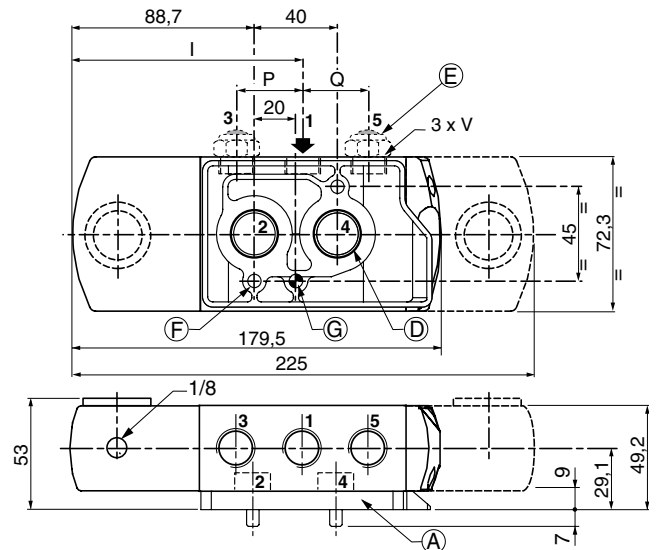

	type	I	P	Q	V
552	01 à 12	111,3	29,6	29,7	3/8
553	01 to 12	112,3	31,6	31,8	1/2

- (A) Interface plates
- (B) 2 mounting holes dia. 5,3; Spotfacing: dia. 9, depth 5 mm
- (C) 1 dia. 5 mm hole for dowel pin (series 551)
 - in position C1: 3/2 NC function plate
 - in position C2: 5/2 function plate
- (D) 2 O-ring seals (supplied)
- (E) Exhaust reducers G 1/8 (series 551) or protectors adaptable on orifices 3 and 5
- (F) 2 mounting holes dia. 6.5 ; Spotfacing: dia. 11, depth 6 mm
- (G) 1 dia. 6,5 mm hole for dowel pin (series 551-552). Same position for interface plate 3/2 NC or 5/2

DIMENSIONS (mm), WEIGHT (kg)



TYPE 01:
SC
Epoxy moulded
IEC 335 / ISO 4400

551B401/B402/B401MO/B402MO/B465/B466/B465MO/B466MO
552A401/A402/A401MO/A402MO/A465/A466/A465MO/A466MO
553A401/A402/A401MO/A402MO/A465/A466/A465MO/A466MO

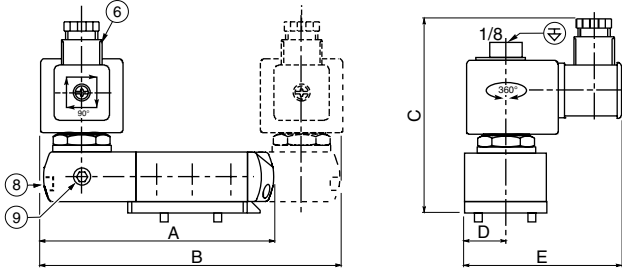

TYPE 02:
NF / WSNF
Aluminium; epoxy coated / AISI 316 SS
EN/IEC 60079-1 and EN/IEC 60079-31

551B401/B402/B401MO/B402MO/B465/B466/B465MO/B466MO
552A401/A402/A401MO/A402MO/A465/A466/A465MO/A466MO
553A401/A402/A401MO/A402MO/A465/A466/A465MO/A466MO

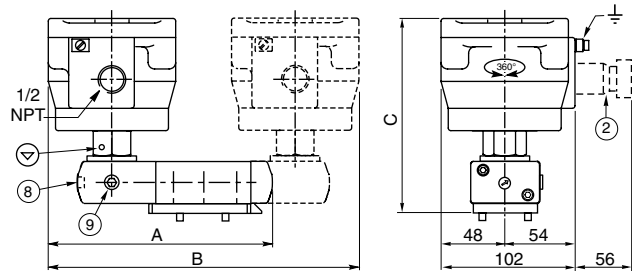

TYPE 04:
WP / WS
EM / WSEM
Steel; epoxy coated / AISI 316 SS
IEC 335 / EN 60079-7/18 and EN 61241-1

551B401/B402/B401MO/B402MO/B465/B466/B465MO/B466MO
552A401/A402/A401MO/A402MO/A465/A466/A465MO/A466MO
553A401/A402/A401MO/A402MO/A465/A466/A465MO/A466MO

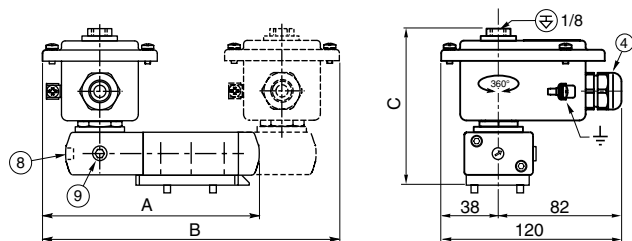

TYPE 05:
PV
Epoxy encapsulated
EN/IEC 60079-18 and EN/IEC 61241-18

551B401/B402/B401MO/B402MO/B465/B466/B465MO/B466MO
552A401/A402/A401MO/A402MO/A465/A466/A465MO/A466MO
553A401/A402/A401MO/A402MO/A465/A466/A465MO/A466MO

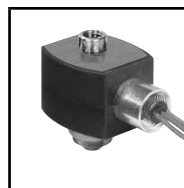
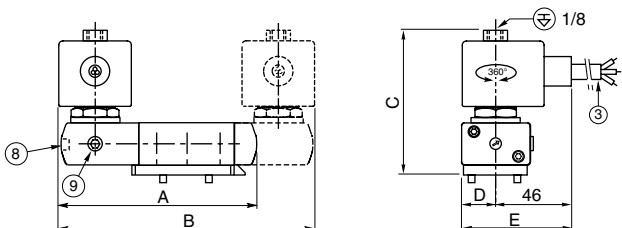

TYPE 06:
EF: NEMA type 7 and 9
Epoxy encapsulated
ICS-6 ANSI
NOTE: applicable to solenoid only

551H401/H402/H401MO/H402MO/H465/H466/H465MO/H466MO
552G401/G402/G401MO/G402MO/G465/G466/G465MO/G466MO
553G401/G402/G401MO/G402MO/G465/G466/G465MO/G466MO

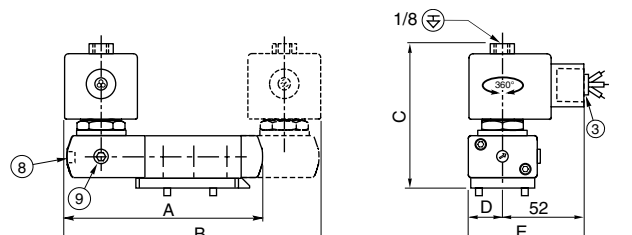

DIMENSIONS (mm), WEIGHT (kg)



TYPE 07:
SC
Epoxy moulded
IEC 335 / ISO 4400

551B301/B302/B301MO/B302MO/B365/B366/B365MO/B366MO
552A301/A302/A301MO/A302MO/A365/A366/A365MO/A366MO
553A301/A302/A301MO/A302MO/A365/A366/A365MO/A366MO

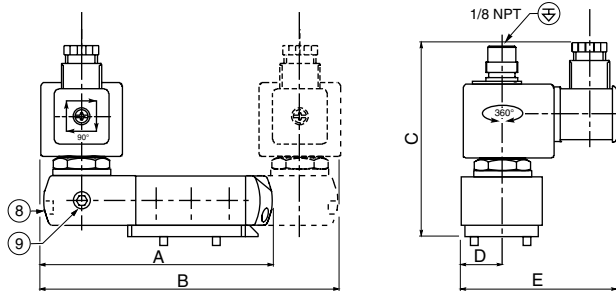

TYPE 08:
NF / WSNF
Aluminium; epoxy coated / AISI 316 SS
EN/IEC 60079-1 and EN/IEC 60079-31

551B301/B302/B301MO/B302MO/B365/B366/B365MO/B366MO
552A301/A302/A301MO/A302MO/A365/A366/A365MO/A366MO
553A301/A302/A301MO/A302MO/A365/A366/A365MO/A366MO

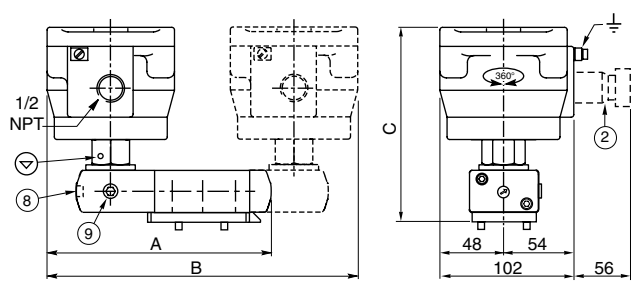

TYPE 09:
WP / WS
EM / WSEM
Steel; epoxy coated / AISI 316 SS
IEC 335/EN 60079-7/18 and EN 61241-1

551B301/B302/B301MO/B302MO/B365/B366/B365MO/B366MO
552A301/A302/A301MO/A302MO/A365/A366/A365MO/A366MO
553A301/A302/A301MO/A302MO/A365/A366/A365MO/A366MO

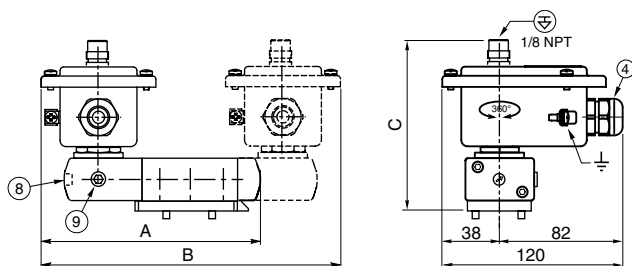

TYPE 10:
PV
Epoxy encapsulated
EN/IEC 60079-18 and EN/IEC 61241-18

551B301/B302/B301MO/B302MO/B365/B366/B365MO/B366MO
552A301/A302/A301MO/A302MO/A365/A366/A365MO/A366MO
553A301/A302/A301MO/A302MO/A365/A366/A365MO/A366MO

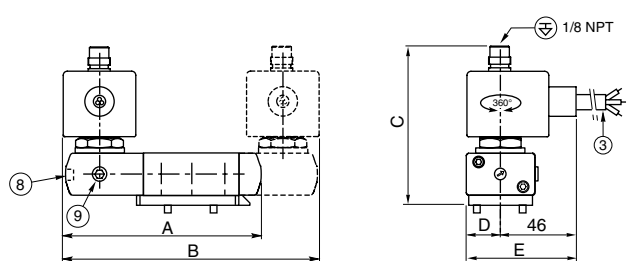

TYPE 11:
EF: NEMA type 7 and 9
Epoxy encapsulated
ICS-6 ANSI
NOTE: applicable to solenoid only

551H301/H302/H301MO/H302MO/H365/H366/H365MO/H366MO
552G301/G302/G301MO/G302MO/G365/G366/G365MO/G366MO
553G301/G302/G301MO/G302MO/G365/G366/G365MO/G366MO

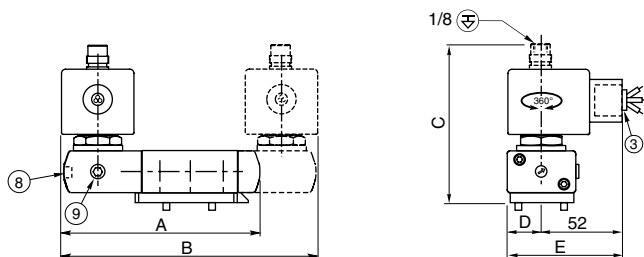

TYPE 12:
ISSC
Polypropylene moulded
Epoxy moulded
IEC 335/EN 60079-11/26 and EN/IEC 61241-11

551B301/B302/B301MO/B302MO/B365/B366/B365MO/B366MO
552A301/A302/A301MO/A302MO/A365/A366/A365MO/A366MO
553A301/A302/A301MO/A302MO/A365/A366/A365MO/A366MO

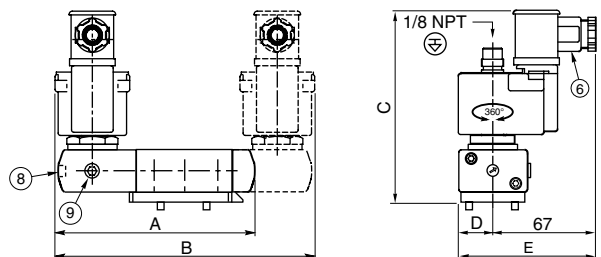

DIMENSIONS (mm), WEIGHT (kg)



TYPE 13 :
LPKF / WSLPKF
Aluminium, cataphoresis black painting / AISI 316L SS
EN/IEC 60079-1 and EN/IEC 61241-1



TYPE 14 :
LI
Aluminium, cataphoresis black painting
IEC and EN: 60079-11, 61241-1

551B301/B302/B301MO/B302MO/B365/B366/B365MO/B366MO
552A301/A302/A301MO/A302MO/A365/A366/A365MO/A366MO
553A301/A302/A301MO/A302MO/A365/A366/A365MO/A366MO

551B301/B302/B301MO/B302MO/B365/B366/B365MO/B366MO
552A301/A302/A301MO/A302MO/A365/A366/A365MO/A366MO
553A301/A302/A301MO/A302MO/A365/A366/A365MO/A366MO

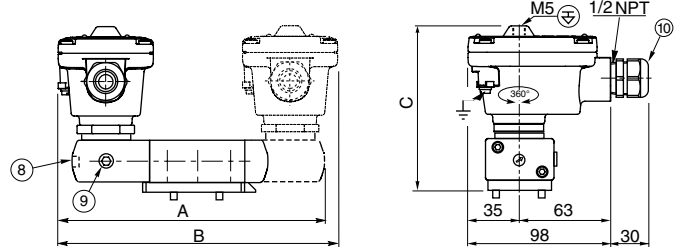
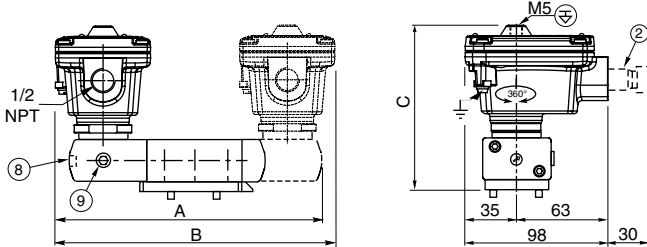

- ② Ex d certified cable gland (on request)
- ③ Three-core cable, length 2 m
- ④ Cable gland for unarmoured cable with 7 to 12 mm dia. sheath
- ⑥ Connector rotatable by 90° increments, cable Ø 6 - 10 mm
- ⑧ Push type or screw type manual operator, suffix MO
- ⑨ External pilot air supply, 1/8 pipe size
- ⑩ Cable gland for unarmoured cable with 7 to 12 mm dia. sheath
- ⊕ Connectable pilot exhaust port
- ⊖ Non-connectable pilot exhaust port

type	prefix option	plage de puissance	A		B		C		D		E		weight ⁽¹⁾						
			551	552/553	551	551 (W1-W3)	552/553	551	552/553	551	552/553	551	552/553	monostable			5/2 bistable - 5/3		
														551	552	553	551	552	553
01	SC	BP	125	179,5	174	198,5	225	107,7	121,2	22,5	36,15	86,5	100,2	0,86	1,76	1,66	1,37	2,32	2,22
02	NF / WSNF	BP	152	224,3	218	241,5	314,6	146,8	160,3	-	-	-	-	1,90	2,80	2,70	3,45	4,46	4,36
04	WP / WS	BP	142	196,2	198	221,5	258,3	108	121,5	-	-	-	-	0,89	1,77	1,67	1,43	2,34	2,24
04	(WS)EM	BP	142	196,2	198	221,5	258,3	108	121,5	-	-	-	-	0,89	1,77	1,67	1,43	2,34	2,24
05	PV	BP	126	179,5	166	189,5	225	93	106,5	22,5	36,15	67,5	81,2	0,87	1,77	1,67	1,39	2,33	2,23
06	EF	BP	126,5	183	167	190,5	232	90,5	104	22,5	36,15	74,5	88,2	0,88	1,77	1,67	1,40	2,34	2,24
07	SC	LP	126,5	180,5	167	190,5	227	106,5	120	22,5	36,15	87,5	101,2	0,86	1,97	1,87	1,61	2,53	2,43
08	NF / WSNF	LP	152	224,3	218	241,5	314,6	146,8	160,3	-	-	-	-	1,90	2,80	2,70	3,45	4,46	4,36
09	WP/WS/(WS)EM	LP	142	196,2	198	221,5	258,3	107,2	120,7	-	-	-	-	1,10	1,98	1,88	1,43	2,55	2,45
10	PV	LP	126	179,5	166	189,5	225	105,5	119	22,5	36,15	67,5	81,2	1,08	1,98	1,88	1,60	2,54	2,44
11	EF	LP	126,5	183	167	190,5	232	105,5	119	22,5	36,15	74,5	88,2	1,07	1,98	1,88	1,59	2,55	2,45
12	ISSC	LP	116	182	169	192,5	230	129,5	143	22,5	36,15	89,5	103,5	0,90	1,80	1,70	1,46	2,36	2,26
13	LPKF	LP	135	191,5	186	152,5	249	118	131,5	-	-	-	-	1,00	2,17	2,07	1,65	2,62	2,52
13	WSLPKF	LP	135	191,5	186	152,5	249	118	131,5	-	-	-	-	1,61	2,77	3,08	2,85	3,82	3,59
14	LI	LP	135	191,5	186	152,5	249	118	131,5	-	-	-	-	1,01	2,18	2,08	1,66	2,63	2,53

⁽¹⁾ Including coil(s) and connector(s).

ACCESSORIES

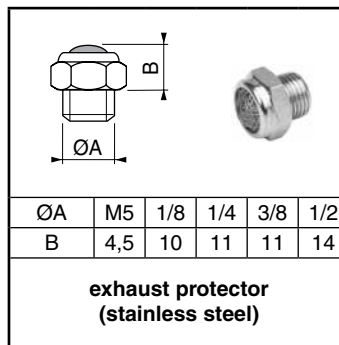
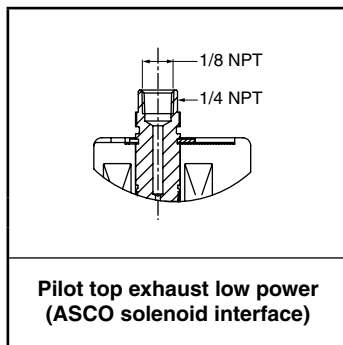
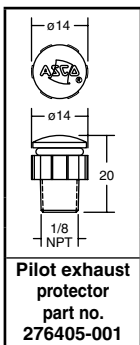



SOLENOID VALVES

pilot operated, spool type
single/dual solenoid (mono/bistable function)
aluminium body, "NAMUR" style, 1/4 to 1/2

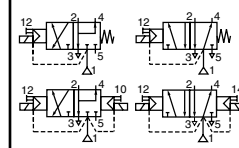

3/2

5/2

Series

551-552-553

FEATURES

- The monostable spool valves have TÜV-EXIDA certified IEC 61508 Functional Safety data and can be used up to SIL 4 (551/TÜV)-SIL 3 (552-553/EXIDA)
- The spool valves have threaded port connections and "NAMUR" style interface
- The same spool valve can be adapted for 3/2 NC or 5/2 function for controlling double-acting and single-acting actuators
- All the exhaust ports of this spool valve are connectable, providing better environmental protection, particularly recommended for sensitive areas such as clean rooms, and applications in the pharmaceutical and food processing sectors
- The valve offers environmental protection against the ingress of liquids, dusts or any other foreign matter (environmentally-protected construction)
- Ultra low power level for inside application, suitable to connect to process fieldbus remote I/O or valve couplers
- The solenoid valves satisfy all relevant EC Directives

GENERAL

Differential pressure 2 - 10 bar [1 bar = 100 kPa]
Flow (Qv at 6 bar) 1/4 = 700 l/min (ANR)
3/8 - 1/2 = 3000 l/min

fluids (*)	temperature range (TS)	seal materials (*)
air, inert gas, filtered	- 25°C to + 40°C ⁽¹⁾	NBR (nitrile) + PUR (polyurethane)
	- 25°C to + 60°C	

⁽¹⁾ With series 302 pilots, suffixes CFSC/CFVT/CFSCIS/CFSCZN

MATERIALS IN CONTACT WITH FLUID

(*) Ensure that the compatibility of the fluids in contact with the materials is verified

Body	Aluminium, black anodized
End cover (spring)	Glass-filled PA
Interface plates	Glass-filled PA
Spool valve internal parts	Zamak, stainless steel, (POM), aluminium
Pilot internal parts	Size 30 (E06.05.80), refer to specific catalogue pages: 374 pilots (CTNK) and 195 (ISSC) Size 15 (E06.36.120N), refer to specific catalogue pages: 302 pilots (CFSC/CFVT/CFSCIS/CFSCZN) and 630 piezotronic (PISC-PISCIS)
Pilot end covers	Aluminium

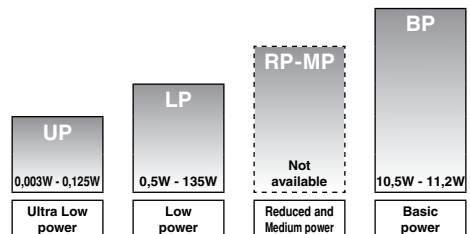
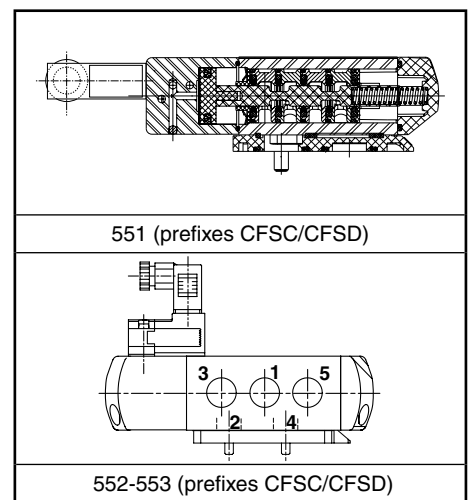

POWER LEVELS - cold electrical holding values (watt)

SPECIFICATIONS

pipe size	orifice size	flow coefficient kv		operating pressure differential (bar)			power level	prefix optional solenoids						basic catalogue number		
				min.	max. (PS)			ATEX / IECEx						CNOMO size 30	CNOMO size 15	
					air (*)	~		=	Ex d	Ex ia		IP65	Ex nA			IP65
(*)	(mm)	(m³/h)	(l/min)				~/=	CTNK	LISC	CFSCIS	PISCIS	CFSC	CFSCZN	PISC		
3/2 NC - 5/2 - Solenoid air pilot operated - spring return (monostable)																
1/4	6	0,6	10	2	10	10	LP	-	-	-	-	●	○	-	-	❖551C501 ⁽²⁾
1/4	6	0,6	10	2	-	8	LP	-	-	○	-	-	-	-	-	❖551C501 ⁽²⁾
1/4	6	0,6	10	2	10	10	BP	●	-	-	-	-	-	-	-	❖551A201 ⁽²⁾
1/4	6	0,6	10	2	-	8	LP	-	○	-	-	-	-	-	-	❖551B201
1/4	6	0,6	10	2	8	8	UP	-	-	-	○	-	-	●	-	❖551C501 ⁽²⁾
3/8	12	2,49	41,5	2	10	10	LP	-	-	-	-	●	○	-	-	❖552A501 ⁽²⁾
3/8	12	2,49	41,5	2	-	8	LP	-	-	○	-	-	-	-	-	❖552A501 ⁽²⁾
3/8	12	2,49	41,5	2	10	10	BP	●	-	-	-	-	-	-	-	❖552A201 ⁽²⁾
3/8	12	2,49	41,5	2	-	8	LP	-	○	-	-	-	-	-	-	❖552B201
3/8	12	2,49	41,5	2	8	8	UP	-	-	-	○	-	-	●	-	❖552A501 ⁽²⁾
1/2	13	2,49	41,5	2	10	10	LP	-	-	-	-	●	○	-	-	❖553A501 ⁽²⁾
1/2	13	2,49	41,5	2	-	8	LP	-	-	○	-	-	-	-	-	❖553A501 ⁽²⁾
1/2	13	2,49	41,5	2	10	10	BP	●	-	-	-	-	-	-	-	❖553A201 ⁽²⁾
1/2	13	2,49	41,5	2	-	8	LP	-	○	-	-	-	-	-	-	❖553A201 ⁽²⁾
1/2	13	2,49	41,5	2	-	8	UP	-	-	-	○	-	-	●	-	❖553A501 ⁽²⁾

❖ Select 8 for NPT ANSI 1.20.3 or select G for ISO G (228/1) ● Available feature ○ Available feature in DC only - Not available
⁽²⁾ Certified IEC 61508 Functional Safety data, use suffix "SL".

SPECIFICATIONS

pipe size	orifice size	flow coefficient kv		operating pressure differential (bar)			power level	prefix optional solenoids							basic catalogue number	
				min.	max. (PS)			ATEX / IECEx				IP65	CNOMO size 30	CNOMO size 15		
					air (*)			Ex d	Ex ia		IP65				Ex nA	
(*)	(mm)	(m³/h)	(l/min)	~	=	~/=	CTNK	LISC	CFSCIS	PISCIS	CFSC	CFSCZN	PISC			
3/2 NC - 5/2 - Solenoid air pilot operated and return (bistable)																
1/4	6	0,6	10	2	10	10	LP	-	-	-	-	●	○	-	-	❖551C502
1/4	6	0,6	10	2	-	8	LP	-	-	○	-	-	-	-	-	❖551C502
1/4	6	0,6	10	2	10	10	BP	●	-	-	-	-	-	-	-	❖551A202
1/4	6	0,6	10	2	-	8	LP	-	○	-	-	-	-	-	-	❖551B202
1/4	6	0,6	10	2	8	8	UP	-	-	-	○	-	-	●	-	❖551C502
3/8	12	2,49	41,5	2	10	10	LP	-	-	-	-	●	○	-	-	❖552A502
3/8	12	2,49	41,5	2	-	8	LP	-	-	○	-	-	-	-	-	❖552A502
3/8	12	2,49	41,5	2	10	10	BP	●	-	-	-	-	-	-	-	❖552A202
3/8	12	2,49	41,5	2	-	8	LP	-	○	-	-	-	-	-	-	❖552B202
3/8	12	2,49	41,5	2	8	8	UP	-	-	-	○	-	-	●	-	❖552A502
1/2	13	2,49	41,5	2	10	10	LP	-	-	-	-	●	○	-	-	❖553A502
1/2	13	2,49	41,5	2	-	8	LP	-	-	○	-	-	-	-	-	❖553A502
1/2	13	2,49	41,5	2	10	10	BP	●	-	-	-	-	-	-	-	❖553A202
1/2	13	2,49	41,5	2	-	8	LP	-	○	-	-	-	-	-	-	❖553B202
1/2	13	2,49	41,5	2	8	8	UP	-	-	-	○	-	-	●	-	❖553A502

PREFIX TABLE

prefix							description	power level			
1	2	3	4	5	6	7		UP	LP	RP	BP
CNOMO solenoid (pilot) interface size 30											
L	I	S	C				Intrinsically safe, pilot 195, ATEX (EN/IEC 60079-11+26, 61241-11)*	-	○	-	-
C	T	N	K				Flameproof with pilot 374, ATEX (EN 60079 / 61241) *	-	-	-	●
CNOMO solenoid (pilot) interface size 15											
C	F	S	C				Solenoid + spade plug AMP 2,5x0,5, 9,4 mm, (EN 60730), 302 pilot	-	●	-	-
C	F	V	T				Solenoid with M12 connection, LED + protection (EN 60730), 302 pilot	-	○	-	-
C	F	S	C	I	S		Intrinsically safe, 9,4 mm, pilot 302; ATEX (EN 60079 / 61241) *	-	○	-	-
C	F	S	C	Z	N		Non sparking, connector 9,4 mm cable 2 m, pilot 302; ATEX (EN 50021) *	-	○	-	-
P	I	S	C				Solenoid with spade plug connector (EN 60730), 630 piezotronic pilot	●	-	-	-
P	I	S	C	I	S		Intrinsically safe, piezotronic 630 pilot, ATEX (EN 60079/61241) *	○	-	-	-

SUFFIX TABLE

suffix					description	power level			
1	2	3	4	5		UP	LP	RP	BP
CNOMO solenoid (pilot) interface size 30									
		M	S		Screw type manual operator ^{(1) (2)}	-	-	-	●
			M		Exhaust reducer (series 551 only)	○	●	-	●
S	L				Certified IEC 61508 Functional Safety data (monostable) ⁽³⁾	-	-	-	●
CNOMO solenoid (pilot) interface size 15									
		M	S		Screw type manual operator ⁽¹⁾	-	●	-	-
		M	O		Push type manual operator	○/●	○/●	-	-
			M		Exhaust reducer (series 551 only)	○/●	●	-	●
S	L				Certified IEC 61508 Functional Safety data (monostable)	○/●	○/●	-	-

OPTIONS & ACCESSORIES

series	pipe size	exhaust protector (stainless steel)		
		(G)	(NPT)	(M)
551	1/8	34600418 ⁽²⁾	34600482 ⁽²⁾	-
552	3/8	34600478 ⁽²⁾	34600480 ⁽²⁾	-
553	1/2	34600479 ⁽²⁾	34600481 ⁽²⁾	-
551/552/553	M5	-	-	34600484 ⁽²⁾

- ❖ Select **8** for NPT ANSI 1.20.3 or select **G** for ISO G (228)
- Available feature
- Available feature in DC only
- Not available
- * ATEX solenoids are also approved according to EN 13463-1 (non electrical valves)
- ⁽¹⁾ Not to use with SL suffix
- ⁽²⁾ Provided with SL suffix
- ⁽³⁾ Not to use with LISC prefix

PRODUCT SELECTION GUIDE

- STEP 1**
Select the fluid temperature range and seal material from the general table on page 15. Select basic catalogue number, including pipe thread identification letter. Refer to the specifications tables on pages 15 and 16.
Example : G552A501
- STEP 2**
Select prefix (combination). Select the appropriate operator from the tables on pages 15 and 16. Select for this operator in the electrical characteristics table on page 17: the power level (UP, LP, BP), the type of electrical enclosure protection and the desired temperature class.
Warning: The ambient temperature range of your application may not exceed the temperature range of your operator.
Example : CFSC
- STEP 3**
Select suffix. Suffix **MO** mandatory for the pilot 302 (CFSCIS/CFSDIS/CFVTIS/CFSCZN/CFVTZN). Refer to the suffix table on page 16, respect the indicated power level.
Example : MO
- STEP 4**
Selection of TPL is mandatory for the 630 pilot (PISCIS), 12 HV DC (32 mW) and 24 HV DC (125 mW). Add "X" between the prefix "PISCIS" and the basic catalogue number.
- STEP 5**
Select voltage.
Refer to standard voltages on page 17.
Example : 230V / 50Hz
- STEP 6**
Final catalogue / ordering number.
Example : CFSCG552A501MO 230 V / 50 Hz

ORDERING EXAMPLES:

CTNK	G	551	A	201	115V / 50 Hz		
CTNK	G	551	A	202	MS	115V / 50 Hz	
CTNK	G	551	A	201	SL	24V / DC	
LISC	G	551	B	201	12,24V / DC		
CFSC	G	552	C	502	230V / 50 Hz		
CFSC	8	552	C	501	MO	230V / 50 Hz	
CFSC	G	552	C	501	SLMO	230V / 50 Hz	
CFVTZN	G	551	C	501	24V / DC		
PISCIS	G	551	C	502	MO	6V / DC	
PISCIS	G	551	C	501	SLMO	6V / DC	
PISCIS X	G	551	C	501	MO	TPL20666	24HV / DC

prefix | pipe thread | basic number | voltage | TPL | suffix

EXPLANATION OF TEMPERATURE RANGES OF SOLENOID VALVES

- Valve temperature range The valve temperature range (TS) is determined by the selected seal material, the temperature range for proper operation of the valve and sometimes by the fluid (e.g. steam)
- Operator ambient temperature range The operator ambient temperature range is determined by the selected power level and the safety code
- Total temperature range The temperature range of the complete solenoid valve is determined by the limitations of both temperature ranges above

ELECTRICAL CHARACTERISTICS

- Coil insulation class F
- Electrical safety IEC 335
- Standard voltages⁽³⁾ DC (=) CTNK : 24V - 48V ; CFSC/CFSCZN/CFVT : 24V
CFSCIS : 12V - 24V ; LISC : 12..24V
PISC : 24V to 70V ; PISCIS : 6V, 8V, 12V, 24V
AC (~) CTNK : 24V - 48V - 115V - 230V/50Hz ; CFSC : 24V - 115V - 230V/50Hz ;
PISC : 24V to 70V - other voltages and 60Hz are available on request

prefix option	power ratings				operator ambient temperature range (TS) (C°)	safety code	electrical enclosure protection (EN 60529)	replacement coil		type ⁽²⁾
	inrush ~ (VA)	holding ~ (VA) (W)		hot/cold = (W)				~	=	
Basic power = BP										
CTNK	55	23	10,5	9/11,2	-20 to +50/60	II 2G/D Ex d IIB+H2 T4/Ex tD	aluminium IP65	-	-	01
Low power = LP										
CFSC	1,4	1,2	1,1	1/1,2	-25 to +60	EN 60730	moulded IP65	-	-	03
CFSC	2,1 ⁽⁷⁾	1,6 ⁽⁷⁾	1,5 ⁽⁷⁾	-	-25 to +60	EN 60730	moulded IP65	-	-	03
CFVT ⁽⁶⁾	-	-	-	1,15/1,35	-25 to +60	EN 60730	moulded IP67	-	-	04
CFSCZN	-	-	-	1/1,2	-25 to +40/55/60	II 3G Ex nA II T6/T5/T4, II 3D Ex tD A22	moulded IP65	-	-	07
CFSCIS ⁽⁴⁾⁽⁵⁾	-	-	-	0,5	-10 to +40/60	II 2G Ex ia IIC T6/T4, II 2D Ex iaD 20	moulded IP65	-	-	09
LISC ⁽³⁾⁽⁴⁾	-	-	-	0,5	-40 to +65	II 1G Ex ia IIC T6 Ga, II 2D Ex ib IIIC Db ⁽³⁾	moulded IP65	-	-	02
Ultra low power = UP										
PISC	-	-	-	0,007	-0 to +60	-	moulded IP65	-	-	06
PISCIS ⁽¹⁾⁽⁴⁾ 6V	-	-	-	0,003	-20 to +50	II 2G Ex ia IIC T6, II 2D Ex iaD 20	moulded IP65	-	-	06
PISCIS ⁽¹⁾⁽⁴⁾ 8V	-	-	-	0,022	-20 to +50	II 2G Ex ia IIC T6, II 2D Ex iaD 20	moulded IP65	-	-	06
PISCIS ⁽¹⁾⁽⁴⁾ 12LV	-	-	-	0,012	-20 to +50	II 2G Ex ia IIC T6, II 2D Ex iaD 20	moulded IP65	-	-	06
PISCIS ⁽¹⁾⁽⁴⁾ 12HV	-	-	-	0,032	-20 to +50	II 2G Ex ia IIC T6, II 2D Ex iaD 20	moulded IP65	-	-	06
PISCIS ⁽¹⁾⁽⁴⁾ 24LV	-	-	-	0,046	-20 to +50	II 2G Ex ia IIC T6, II 2D Ex iaD 20	moulded IP65	-	-	06
PISCIS ⁽¹⁾⁽⁴⁾ 24HV	-	-	-	0,125	-20 to +50	II 2G Ex ia IIC T6, II 2D Ex iaD 20	moulded IP65	-	-	06

⁽¹⁾ Piezotronic standard voltages:

Prefix PISC, 24 V to 70 V AC/DC, peak current max. : 80 mA, holding current max. : 1 mA

Prefix PISCIS:	6 V DC / 3 mW	8 V DC / 22 mW	12L V DC / 12 mW	12H V DC / 32 mW	24L V DC / 46 mW	24H V DC / 125 mW
Turn ON voltage U _{ON}	6 .. 9 V	7,2 .. 12 V	10,8 .. 16 V	10,8 .. 16 V	21,6 .. 28 V	21,6 .. 28 V
Turn OFF voltage U _{OFF}	3 V	3,2 V	3,3 V	3,3 V	5 V	5 V
Peak current	6 mA	10 mA	6,8 mA	8,1 mA	10 mA	14 mA
Holding current	0,5 mA	2,8 mA	1 mA	2,7 mA	1,9 mA	5,2 mA
Cable + max. barrier resistances (R _s + R _c)	1200 Ω max.	300 Ω max.	1200 Ω max.	470 Ω max.	1200 Ω max.	470 Ω max.

prefix option	safety parameters					
	U ₀ (DC) (V)	I ₀ (mA)	P ₀ (W)	L ₀ (H)	C ₀ (μF)	
Low power = LP						
CFSCIS	28	300	1,6	0	0	
LISC	30	300	1,6	0	0	
Ultra low power = UP						
PISCIS	30	200	0,9	0	0	

⁽²⁾ Refer to the dimensional drawings on pages 18 to 20.

⁽³⁾ Min. operating current (I_{(ON) min.}): 0,036 A / U_{(ON) min.} = 12,8 V (For use in zone 0 locations, see the installation conditions given in the I&M instructions)

⁽⁴⁾ Intrinsically safe pilots: Check the electrical characteristics in the corresponding catalogue pages (CFSCIS/LISC/PISCIS: 302/19500036/630 pilots).

⁽⁵⁾ CFSCIS (302 pilots):

12 V : I_{(ON) min.}, with LED = 33 mA; U_{(ON) min.} = 11,9 V; U_(max.) recommended = 23 V; U_(OFF) = 3,3 V; I_(OFF) = 10 mA
24 V : I_{(ON) min.}, with LED = 25 mA; U_{(ON) min.} = 16,4 V; U_(max.) recommended = 28 V; U_(OFF) = 5,7 V; I_(OFF) = 7 mA

⁽⁶⁾ Values for LED + protection.

⁽⁷⁾ AC : 230V

- Not available

ELECTRICAL CONNECTIONS

prefix	connection
CTNK	3/4" NPT threaded cable entry. Enclosures are supplied without cable gland
LISC	Spade plug connector with cable gland EN175301-803A (ISO 4400) for cables with an outer diameter from 6 to 8 mm
CFSC, CFSCIS, PISC, PISCIS	Spade plug connector with cable gland DIN 43650, 9,4 mm, form C, for cables with an outer diameter from 4 to 6 mm
CFVT	M12 connection for M12 connector
CFSCZN	Spade plug connector, DIN 43650, 9,4 mm, form C, pre-wired connector length 2m
CFL	Moulded-in flying lead, standard length 0,3 m

ADDITIONAL OPTIONS

- TPL numbers: TPL **20665**: Piezotronic, PISCIS prefix, 12 HV (32 mW)
 TPL **20666**: Piezotronic, PISCIS prefix, 24 HV (125 mW)
- TPL numbers: TPL **20674**: LED and protection, CFSC prefix - Add 0,15 W (DC) and 0,4 W/VA (AC)
 Only available in 24 V AC/DC and 115 V AC
- Other pipe threads are available on request
- Set of stainless steel mounting screws, catalogue number **97802212** (series 551)
- Set of two exhaust reducers, G1/8, catalogue number **88100344** (series 551)

INSTALLATION

- Installation/maintenance instructions are included with each valve
- The valves can be mounted in any position without affecting operation
- IEC 61508 Functional Safety (Suffix SL), allowable temperature range: -40°C to +60°C. Probability of failure on demand, contact us
- It is necessary to connect pipes or fittings to the exhaust ports to protect the internal parts of the valve if used outside or in harsh environments (dusts, liquids etc.)
- Spool valve supplied with two interface plates with NAMUR mating surfaces. Depending on function (NC 3/2 or 5/2), position one of the two plates on the spool valve body before installing on actuator
- It is necessary to connect pipes or fittings to the exhaust ports to protect the internal parts of the spool valve and its pneumatic operator if used outside or in harsh environments (dusts, liquids etc.)
- Dowel pin (if necessary), bolts and gaskets are standard supplied
- Threaded pipe connection identifier is: 8 = NPT (ANSI 1.20.3); G = G (ISO 228/1)
- Ex d (prefix "CTNK") enclosure is provided with a 3/4" NPT threaded entry hole [optionally, 1/2" NPT (prefix "T") or M20 x 1,5 (prefix "ET")] and is supplied without cable gland
- Valves with suffix "SL" are provided with specific exhaust protectors

DIMENSIONS (mm), WEIGHT (kg)

Series 551

Series 552-553

Types 01 et 02

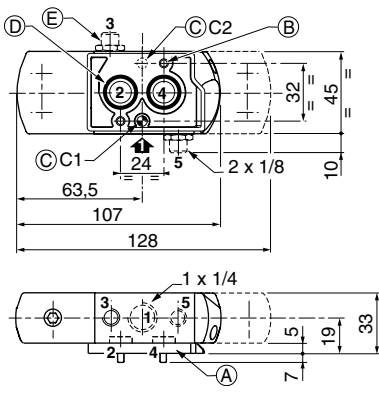

Types 03 to 10

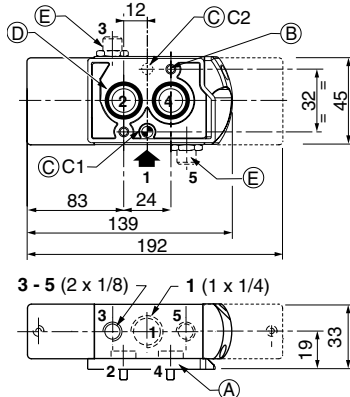

Types 01 to 10

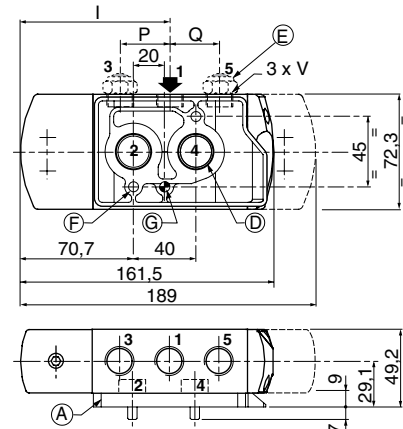

	I	P	Q	V
552	93,3	29,6	29,7	3/8
553	94,3	31,6	31,8	1/2

- (A) Interface plates
- (B) 2 mounting holes dia. 5,3; Spotfacing: dia. 9, depth 5 mm
- (C) 1 dia. 5 mm hole for dowel pin (series 551)
 - in position C1: 3/2 NC function plate
 - in position C2: 5/2 function plate
- (D) 2 O-ring seals (supplied)

- (E) Exhaust reducers G 1/8 (series 551) or protectors adaptable on orifices 3 and 5
- (F) 2 mounting holes dia. 6.5 ; Spotfacing: dia. 11, depth 6 mm
- (G) 1 dia. 6,5 mm hole for dowel pin (series 551-552).
 Same position for interface plate 3/2 NC or 5/2

DIMENSIONS (mm), WEIGHT (kg)



TYPE 01:
CTNK
 Light alloy, cataphoresis black painting
 EN 60079-1 and EN 61241-1

551A201MS / A202MS
 552A201MS / A202MS
 553A201MS / A202MS



TYPE 02:
LISC
 Aluminium
 IEC 335/EN 60079-11/26 and EN/IEC 61241-11

551B201 / B202
 552B201 / B202
 553B201 / B202

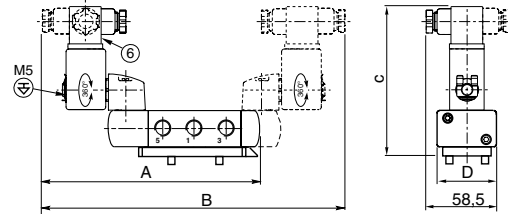
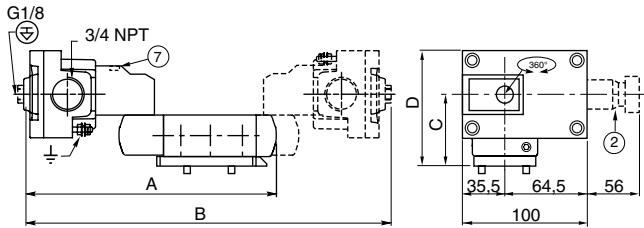

TYPE 03:
CFSC
 302 pilot
 Polyarylamide
 IEC 335 / DIN 43650

551C501 / 551C502
 551C501MS / 551C501MO / C502MS / C502MO

552A501 / A501MS / A501MO / A502 / A502MS / A502MO
 553A501 / A501MS / A501MO / A502 / A502MS / A502MO

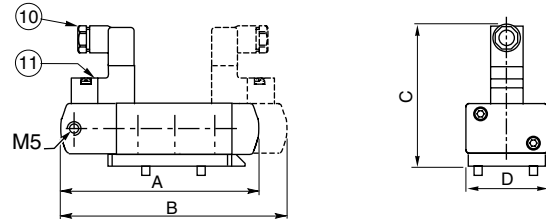
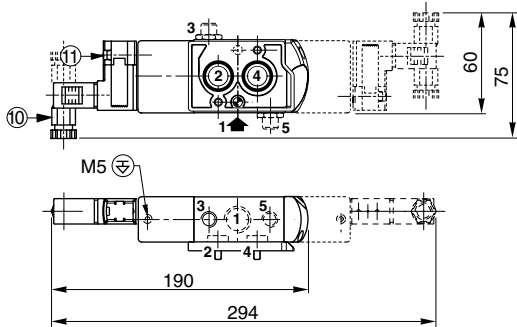

TYPE 04:
CFVT
 302 pilot
 Polyarylamide
 IEC 335 / connection M12 + LED and protection

551C501 / 551C502
 551C501MS / 551C501MO / C502MS / C502MO

552A501 / A501MS / A501MO / A502 / A502MS / A502MO
 553A501 / A501MS / A501MO / A502 / A502MS / A502MO

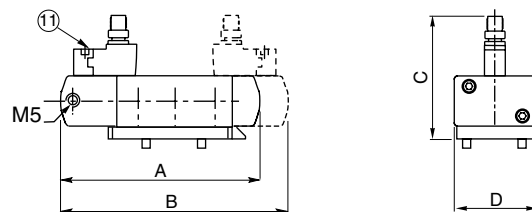
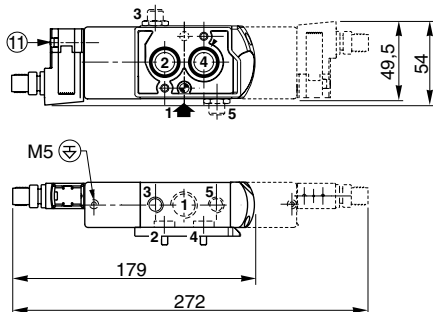

DIMENSIONS (mm), WEIGHT (kg) 



TYPE 06:
 PICS / PISCIS
 Piezotronic pilot
 Polyamide
 IEC 335 / DIN 43650
 EN 60079-11/26 and EN 61241-11

551C501MO / 551C502MO

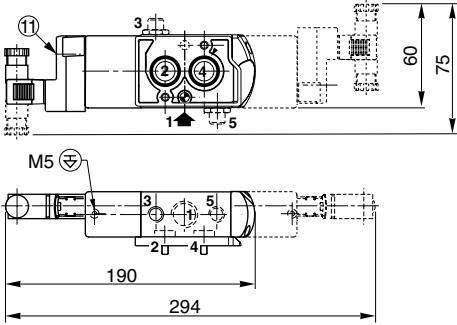

552A501MO / A502MO
 553A501MO / A502MO

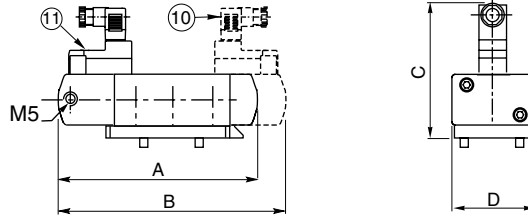

TYPE 07:
 CFSCZN
 302 pilot
 Polyarylamide
 IEC 335 / DIN 43650, cable 2 m
 EN 60079-15 and EN 61241-1

551C501MO / 551C502MO

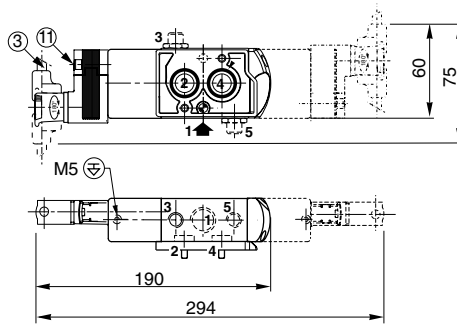

552A501MO / A502MO
 553A501MO / A502MO

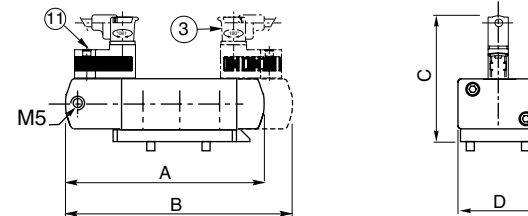

TYPE 09:
 CFSCIS
 302 pilot
 Polyarylamide
 IEC 335 / DIN 43650
 EN/IEC 60079-11/26 and EN/IEC 61241-11

551C501MO / 551C502MO

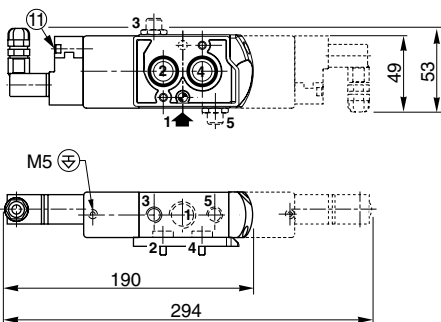

552A501MO / A502MO
 553A501MO / A502MO

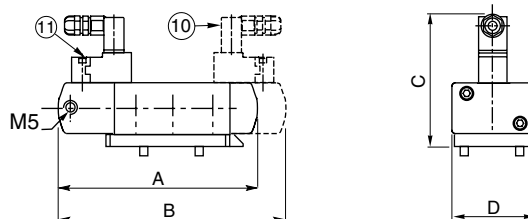

DIMENSIONS (mm), WEIGHT (kg)

- ② Ex d certified cable gland (on request)
- ⑥ Connector rotatable by 90° increments, cable Ø 6 - 8 mm
- ⑦ Screw type manual operator, suffix MS
- ⑧ Push type or screw type manual operator, suffix MO
- ⑩ Connector rotatable by 90° increments, cable Ø 6 - 7 mm
- ⑪ Push type manual operator, suffix MO
- ⊕ Connectable pilot exhaust port
- ⊖ Non-connectable pilot exhaust port

type	prefix option	power level	A		B		C		D		E		weight ⁽¹⁾					
			monostable			bistable												
			551	552/553	553	551	552/553	553	551	552/553	553	551	552	553	551	552	553	
01	CTNK	BP	177	244	270	355	48	64,7	77	98,7	-	-	1,12	1,97	1,87	1,86	3,05	2,95
02	LISC	LP	158	231,5	216	311	112	125,5	45	72,3	-	-	0,59	1,44	1,34	0,80	2,52	2,42
03	CFSC	LP	-	161,5	-	189	-	99,2	-	72,3	-	-	0,33	1,10	1,00	0,38	2,18	2,08
04	CFVT	LP	-	161,5	-	189	-	90,2	-	72,3	-	-	0,33	1,12	1,02	0,38	2,22	2,12
06	PISC / PISCIS	UP	-	161,5	-	189	-	99,2	-	72,3	-	-	0,31	1,10	1,00	0,32	2,18	2,08
07	CFSCZN	LP	-	161,5	-	189	-	99,2	-	72,3	-	-	0,41	1,18	1,08	0,54	2,34	2,24
09	CFSCIS	LP	-	161,5	-	189	-	100,2	-	72,3	-	-	0,34	1,12	1,02	0,4	2,22	2,12

⁽¹⁾ Including coil(s) and connector(s).

ACCESSORIES

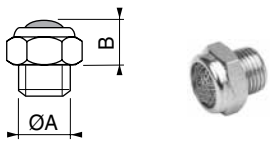

ØA	M5	1/8	1/4	3/8	1/2
B	4,5	-	11	11	14

**exhaust protector
(stainless steel)**

SPOOL VALVES

pilot operated, spool type
single/dual solenoid (mono/bistable function)
aluminium body, NAMUR, 1/4

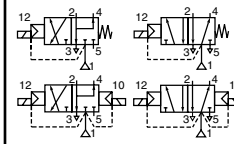

3/2
5/2
Series
551

FEATURES

- Solenoid pilot valve 3/2 with flapper/nozzle technology for long service life
- Ultra power low pilot (**0,03 W**) for use in potentially explosive atmospheres according to ATEX-Directive 94/9/EC
EC type-examination certificate no.: **LCIE 07 ATEX 6080 X**
- Pilot associated to a series 551 valve 3/2 NC or 5/2 with aluminium body for control of actuators in the pharmaceutical, fine chemical and process industries
- The pilot's intrinsic safe (Ex ia) protection allows it to be installed in hazardous zone 1 or 2. It is compatible with all safety barrier brands
- The spool valves have threaded port connections and "NAMUR" style interface
- Exhaust ports of this spool valve connectable for better environmental protection
- The valve offers environmental protection against the ingress of liquids, dusts or any other foreign matter (environmentally-protected construction)
- The solenoid valves satisfy all relevant EC Directives

GENERAL

Differential pressure 2 - 8 bar [1 bar = 100 kPa]
Flow (Qv at 6 bar) 700 l/min (ANR)

fluids (*)	temperature range (TS)	seal materials (*)
air, inert gas, dry, filtered	- 40°C to + 60°C	NBR (nitrile) + PUR (polyurethane)

MATERIALS IN CONTACT WITH FLUID

(*) Ensure that the compatibility of the fluids in contact with the materials is verified

Body	Aluminium, black anodised
Interface plates	Glass-filled PA
End cover (spring return)	PBT
Pilot end covers	Aluminium
Spool valve internal parts	Stainless steel, POM, aluminium
Pilot housing	PBT reinforced (thermoplastic polyester)
Pilot seals	NBR + VMQ (silicone)

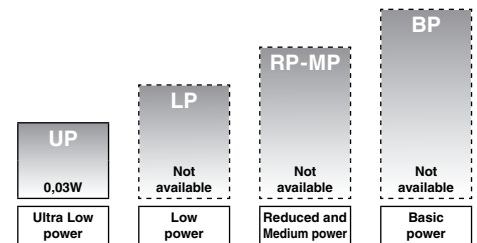
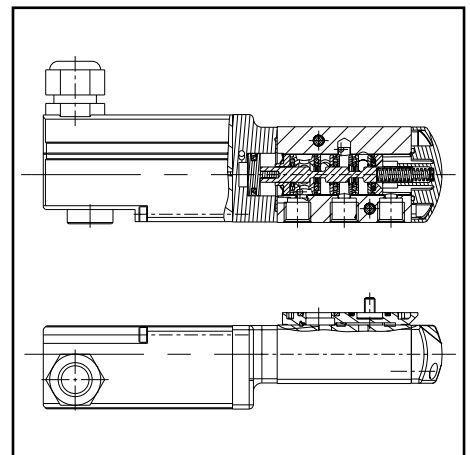

POWER LEVELS - cold electrical holding values (watt)

SPECIFICATIONS

pipe size	orifice size	flow coefficient kv		operating pressure differential (bar)			power level	prefix optional solenoids							basic catalogue number	
								ATEX / IECEx								
				min.	max. (PS)			Ex ia								
(*)	(mm)	(m³/h)	(l/min)		air (*)		~/=		Ex ia							
				~	=	~/=		CTPV								
Solenoid air pilot operated - spring return (monostable)																
1/4	6	0,75	12,5	2	-	8	UP	-	○	-	-	-	-	-	-	❖551A682
Solenoid air pilot operated and return (bistable)																
1/4	6	0,75	12,5	2	-	8	UP	-	○	-	-	-	-	-	-	❖551A684

❖ Select 8 for NPT ANSI 1.20.3 or select G for ISO G (228/1) ○ Available feature in DC only - Not available

PREFIX TABLE

prefix							description	power level			
1	2	3	4	5	6	7		UP	LP	RP	BP
Solenoid (pilot) interface											
C	T	P	V				Intrinsically safe with pilot 19500033, ATEX (EN 60079) *	○	-	-	-

PRODUCT SELECTION GUIDE

STEP 1

Select the fluid temperature range and seal material from the general table on page 23. Select basic catalogue number, including pipe thread identification letter. Refer to the specifications tables on page 23.

Example : G551A682

STEP 2

Select prefix (combination). Select the appropriate operator from the tables on page 23. Select for this operator in the electrical characteristics table on page 25: the power level (UP), the type of electrical enclosure protection and the desired temperature class.

Warning: The ambient temperature range of your application may not exceed the temperature range of your operator.

Example : CTPV

STEP 3

Select voltage.

Refer to standard voltages on page 24.

Example : 16..40V / DC

STEP 4

Final catalogue / ordering number.

Example :

CTPVG551A682 16..40V / DC

OPTIONS & ACCESSORIES

series	pipe size	exhaust protector (stainless steel)		fitting with inlet filter 0,1 mm and seal
		(G)	(NPT)	(G)
551	1/4	34600419	34600483	88100931

❖ Select **8** for NPT ANSI 1.20.3 or select **G** for ISO G (228/1)

● Available feature

○ Available feature in DC only

- Not available

* ATEX solenoids are also approved to EN 13463-1 (non electrical valves)

ORDERING EXAMPLES:

CTPV	G	551	A	682	24V / DC
CTPV	8	551	A	684	24V / DC
prefix					voltage
pipe thread					TPL
basic number					suffix

EXPLANATION OF TEMPERATURE RANGES OF SOLENOID VALVES

Valve temperature range	The valve temperature range (TS) is determined by the selected seal material, the temperature range for proper operation of the valve and sometimes by the fluid (e.g. steam)
Operator ambient temperature range	The operator ambient temperature range is determined by the selected power level and the safety code
Total temperature range	The temperature range of the complete solenoid valve is determined by the limitations of both temperature ranges above

ELECTRICAL CHARACTERISTICS

Coil insulation class	B
Electrical safety	IEC 335
Voltage range	DC (=) CTPV : 16 to 40 V

prefix option	power ratings			operator ambient temperature range (TS) (C°)	safety code	electrical enclosure protection (EN 60529)	replacement coil		type ⁽²⁾	
	inrush ~ (VA)	holding ~ (VA) (W)	hot/cold = (W)				~	=		
	-	-	-				-	-		
Ultra low power (UP)										
CTPV ⁽¹⁾	-	-	-	0,04/0,03	-40 to +80/+50	II 2G Ex ia IIC T5/T6	moulded IP65	-	-	01

⁽¹⁾ Prefix CTPV, U_{max} : 16 to 40 V DC; Max. current consumption : I_{max} : 2,5 to 6,7 mA; P_{max} : 40 to 270 mW
8080 Ω at +80°C ≤ Internal resistance (Ω) ≥ 5000 Ω at +40°C

prefix option	safety parameters				
	U _{i=} (DC) (V)	I _i (mA)	P _i (W)	L _i (H)	C _i (μF)
Ultra low power (UP)					
CTPV	40	200	0,75	0	0

⁽²⁾ Refer to the dimensional drawings on page 26.
- Not available

ELECTRICAL CONNECTIONS

prefix	connection
CTPV	M20 cablegland for cables with an outer diameter from 5 to 9 mm

ADDITIONAL OPTIONS

• Other pipe threads are available on request

INSTALLATION

<ul style="list-style-type: none"> • Installation/maintenance instructions are included with each valve • The valves can be mounted in any position without affecting operation • Spool valve supplied with two interface plates with NAMUR mating surfaces. Depending on function (NC 3/2 or 5/2), position one of the two plates on the spool valve body before installing on actuator • It is recommended to protect the pilot with an inlet filter G 1/4, catalogue number 88100931 • It is necessary to connect pipes or fittings to the exhaust ports to protect the internal parts of the valve if used outside or in harsh environments (dusts, liquids etc.) • Dowel pin (if necessary), bolts and gaskets are standard supplied • Threaded pipe connection identifier is: 8 = NPT (ANSI 1.20.3); G = G (ISO 228/1)

DIMENSIONS (mm), WEIGHT (kg)



TYPE 01:
CTPV
Aluminium
IEC 335 / ISO 4400
EN 60079-11

551A682

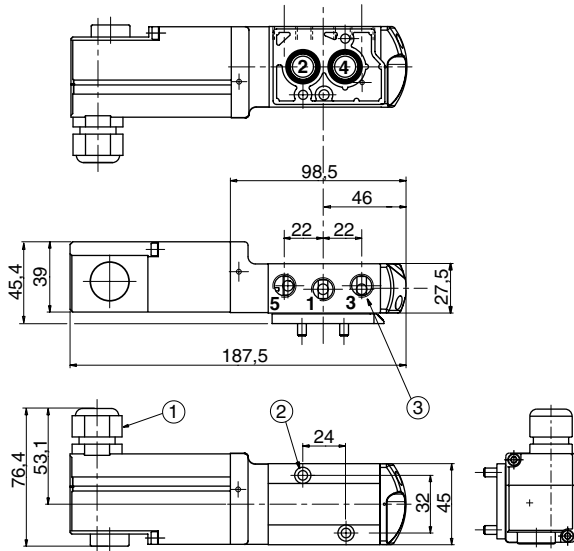

551A684

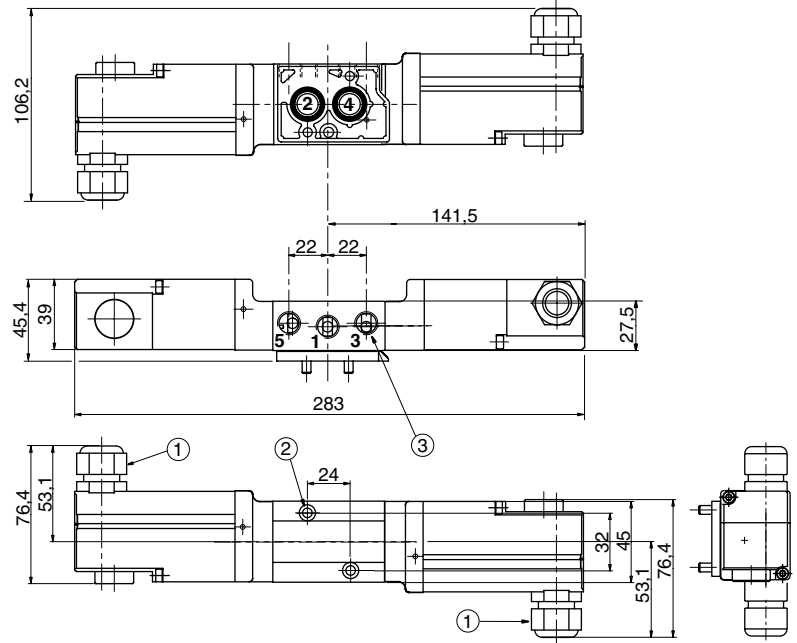

- ① Cable gland for unarmoured cable with 5 to 9 mm dia. sheath
- ② 2 mounting holes dia. 5,3 mm Spotfacing: dia. 9 mm, depth 5 mm
- ③ 3 x 1/4

type	prefix option	power level	weight ⁽¹⁾	
			monostable	bistable
01	CFVT	UP	0,475	0,755

⁽¹⁾ Without cable.

ACCESSORIES

<table border="1"> <tr> <td>ØA</td> <td>-</td> <td>-</td> <td>1/4</td> <td>-</td> <td>-</td> </tr> <tr> <td>B</td> <td>-</td> <td>-</td> <td>11</td> <td>-</td> <td>-</td> </tr> </table>	ØA	-	-	1/4	-	-	B	-	-	11	-	-	<table border="1"> <tr> <td>ØA</td> <td>-</td> <td>-</td> <td>1/4</td> </tr> <tr> <td>B</td> <td>-</td> <td>-</td> <td>19</td> </tr> </table>	ØA	-	-	1/4	B	-	-	19
ØA	-	-	1/4	-	-																
B	-	-	11	-	-																
ØA	-	-	1/4																		
B	-	-	19																		
exhaust protector (stainless steel)	fitting with inlet filter 100 µm and seal																				